

Compact hydraulic power pack type INKA 1

Product documentation



For short period operation (S2), periodic intermittent operation (S3)

Operating pressure p_{\max} :	700 bar
Displacement volume V_{\max} :	1.5 cm ³ /rev
Usable volume $V_{\text{use max}}$:	1.65 l



© by HAWE Hydraulik SE.

The reproduction and distribution of this document, as well as the use and communication of its contents to others without explicit authorization, is prohibited.

Offenders will be held liable for the payment of damages.

All rights reserved in the event of patent or utility model applications.

Brand names, product names and trademarks are not specifically indicated. In particular with regard to registered and protected names and trademarks, usage is subject to legal provisions.

HAWE Hydraulik respects these legal provisions in all cases.

HAWE Hydraulik cannot provide individual guarantees that the stated circuits or procedures (including in part) are not subject to the intellectual property rights of third parties.

Printing date / document generated on: 2024-04-05

Table of Contents

1	Overview of compact hydraulic power pack type INKA 1.....	5
2	Available versions.....	6
2.1	Motor and container.....	7
2.1.1	Basic type and motor power.....	7
2.1.2	Tank size.....	7
2.1.3	Installation position.....	8
2.1.4	Rotation of the top housing cover.....	9
2.1.5	Additional option: sensor system.....	10
2.1.6	Switch output.....	12
2.1.7	Electrical connection.....	13
2.1.8	Additional option: electric.....	13
2.1.9	Additional option: external fan.....	13
2.1.10	Drain hose for hydraulic fluid.....	14
2.1.11	Version.....	14
2.2	Pump.....	15
2.2.1	Pump with 3-phase motor.....	15
2.2.2	Pump with AC motor.....	18
3	Parameters.....	21
3.1	General data.....	21
3.2	Pressure and volumetric flow.....	22
3.3	Weight.....	23
3.4	Characteristic lines.....	24
3.4.1	Build-up of heat.....	24
3.4.2	Running noise.....	26
3.5	Electrical data.....	28
3.6	Motor data.....	29
3.6.1	Current consumption characteristic lines.....	30
3.7	Additional options.....	31
3.7.1	Additional option: sensor system.....	31
3.7.2	External fan.....	31
4	Dimensions.....	32
4.1	Mounting hole pattern.....	32
4.2	Pump.....	33
4.2.1	Vertical version.....	33
4.2.2	Horizontal version.....	34
4.2.3	Additional options.....	35
4.3	Connections.....	38
4.3.1	Hydraulic connections.....	38
4.3.2	Electrical connections.....	40
5	Installation, operation and maintenance information.....	43

6	Other information.....	44
6.1	Planning information.....	44
6.1.1	Drawing up function diagram.....	44
6.1.2	Determining pressures and flow rates.....	44
6.1.3	Creating a hydraulic circuit diagram.....	45
6.1.4	Drawing up a time/load diagram on the basis of a function diagram.....	45
6.1.5	Selecting the compact hydraulic power pack.....	45
6.1.6	Calculating the hydraulic work value.....	46
6.1.7	Determining the steady-state temperature.....	47
6.1.8	Determining the maximum current consumption.....	47
6.1.9	Selecting the operating capacitor.....	48
6.1.10	Setting the pump after-run.....	48
6.1.11	Connection blocks.....	49
6.1.12	Planning directional valve banks.....	50

1 Overview of compact hydraulic power pack type INKA 1

Compact hydraulic power packs are a type of hydraulic power pack. They are characterised by a highly compact design, since the motor shaft of the electric motor also acts as the pump shaft. Compact hydraulic power packs are designed to supply hydraulic circuits with hydraulic fluid.

The compact hydraulic power pack type INKA consists of the tank, the integrated motor and the radial piston pump or gear pump directly attached to the motor shaft. The directly mounted electronic communication box with integrated real-time operating system allows the operating state to be recorded and visualised. The measured values of the integrated multi-sensor (including the motor speed) can be passed on to the higher-level machine controls via standardised interfaces and processed there.

The consistently modular design of the type INKA means that different usage volumes and flow rates can be realised quickly and easily from the modular system. Compatible, ready-for-connection, complete solutions can be assembled easily using a wide range of connection blocks and the valve banks that can be combined with them.

Features and advantages

- Prepared for condition monitoring with integrated sensors and communication box
- Optimum efficiency through under-oil motor cooling, direct power transmission, and sophisticated heat dissipation
- Resource-saving due to small oil filling volume

Intended applications

- Machine tools and material testing
- Hydraulic tools
- Handling systems
- Presses and processing machines



Compact hydraulic power pack type INKA 1

2 Available versions

Circuit symbol

with sensors and external fan

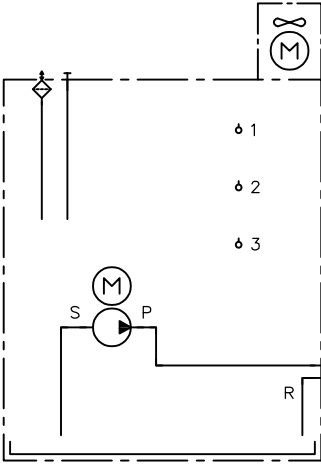

without sensors

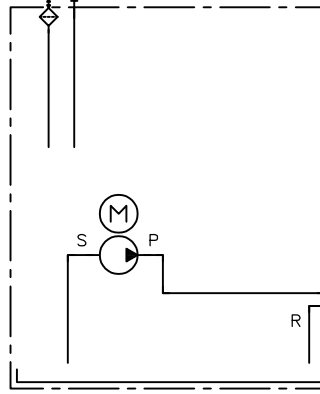

Ordering examples

INKA 14	2	V	21	-H0.64	-E2	T40T60T80	-P0	X	F150	-G0	-0	-3 x 400 V 50 Hz-0.55kW	-...
INKA 14	1	H	00	-Z2.25	-E2	T80D00E00	-P0	X	F000	-G0	-0	-3 x 400 V 50 Hz-0.25kW	-...
INKA 14	1	V	00	-HD..	-E0	X00X00X00	-P1	E	F10L	-G0	-0	-3 x 400 V 50 Hz-0.25kW	-...

													6.1.11 "Connection blocks"
													3.6 "Motor data"
													2.1.11 "Version"
													2.1.10 "Drain hose for hydraulic fluid"
													2.1.9 "Additional option: external fan"
													2.1.8 "Additional option: electric"
													2.1.7 "Electrical connection"
													2.1.6 "Switch output"
													2.1.5 "Additional option: sensor system"
													2.2 "Pump"
													2.1.4 "Rotation of the top housing cover"
													2.1.3 "Installation position"
													2.1.2 "Tank size"
													2.1.1 "Basic type and motor power"

2.1 Motor and container

2.1.1 Basic type and motor power

Type	For motor voltages and motor data, see Chapter 3.6, "Motor data"		
	Nominal voltage	Nominal power (kW)	Rated speed (rpm) at 50 Hz / 60 Hz
3-phase motor, 4-pole			
INKA 14	3x400 V 50 Hz / 460 V 60 Hz	0.25	1400 / 1730
	3x230 V 50 Hz / 265 V 60 Hz	0.25	1400 / 1730
	3x200 V 50 Hz / 220 V 60 Hz	0.25	1400 / 1710
	3x400 V 50 Hz / 460 V 60 Hz	0.55	1380 / 1700
	3x230 V 50 Hz / 265 V 60 Hz	0.55	1380 / 1700
	3x200 V 50 Hz / 220 V 60 Hz	0.55	1380 / 1700
AC motor, 4-pole			
INKA 14	1x230 V 50 Hz	0.37	1380
	1x220 V 60 Hz	0.37	1640
	1x110 V 60 Hz	0.37	1640

2.1.2 Tank size

Coding	Vertical		Horizontal	
	Fill volume (l)	Usable volume (l)	Fill volume (l)	Usable volume (l)
1	1.60	0.55	1.60	0.65
2	2.10	1.05	2.05	0.85
3	2.75	1.65	2.60	1.10



NOTICE

Tank size 1 only available with 3-phase motor 0.25 kW

2.1.3 Installation position

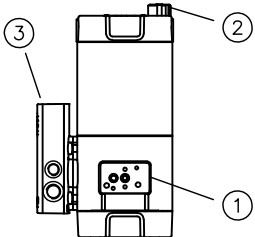
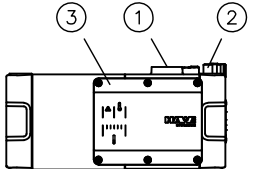
Coding	Comment	Installation position
V	Vertical	
H	Horizontal	

- 1 Connection base
- 2 Filler port and breather filter (hydraulic fluid)
- 3 Communication box

! NOTICE

- The horizontal version can also be incorporated vertically.
- The horizontal version with sensors can be inserted vertically, in which case no measurement of the fluid level is possible.
- The vertical version with radial piston pump (coding H, HD) cannot be used horizontally.
- The vertical version with sensors cannot be inserted horizontally. In this case, neither the sensors (E2 with switch output) nor the filling level display (LED) would work.
- Re 1: set-up of connection block/directional valve bank:
see Chapter 6.1.11, "Connection blocks"

2.1.4 Rotation of the top housing cover

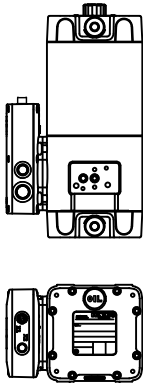
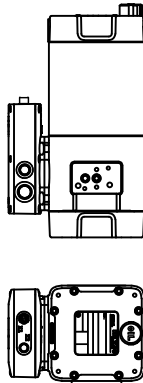
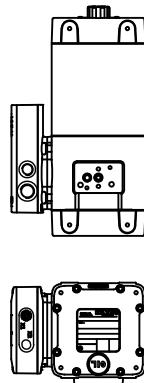
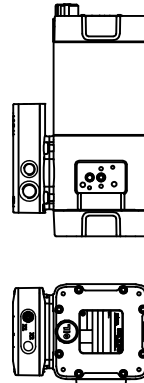
Coding	00	11	22	33
				

! NOTICE

- Covers can only be mounted rotated with the vertical variant (coding V).
For the horizontal variant (coding H), there is only the option with coding 00.
For the horizontal version, the oil filler/ventilation and the connection block must be at the top.
- The top (= 1st digit) and bottom cover (= 2nd digit) can each be mounted independently of the other, rotated in a 90° grid.
- Rotation 1 and 3 of the top cover only possible without additional electronic option (coding E0).

2.1.5 Additional option: sensor system

The optional sensor system can be used to measure the level, the temperature of the hydraulic fluid and the motor speed. The visualisation takes place at the communication box.

The following applies for options E1 and E2: fluid level in the hydraulic power pack is measured capacitively. Not displayed in the case of option E0. The fluid level is visualised by a column of 6 LEDs. The lowest and topmost LEDs are two-colour.

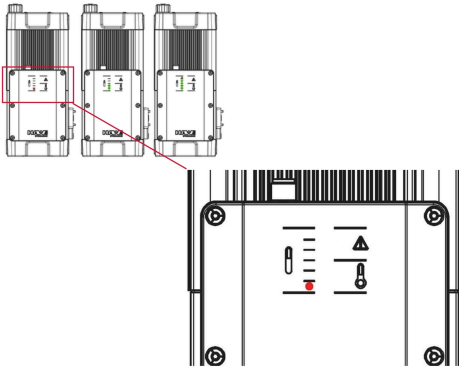

	Fluid level								
	Cannot be measured	0 to 10%	10 to 20%	20 to 40%	40 to 60%	60 to 80%	70 to 80%	80 to 98%	> 98%
LED 6									
LED 5									
LED 4									
LED 3									
LED 2									
LED 1									

Legend

- Single-colour symbols: lit up
- 2-colour symbols: flashing

Coding	Comment
E0	No additional electronic option
E1	Sensors with IO-Link (connection via M12 plug)
E2	Sensors with 3 switch outputs (connection via M12 plug)

Variant sensors

Two variants of the Power Unit Sensor are available:

- IO-Link
- Switch output

Function	Sensors with IO-Link	Sensors with switch output
IO-Link	✓	-
3 switch outputs	-	✓
Visualisation	✓	✓
External fan control	✓	✓
Parametrisation interface	Parametrisation via IO-Link	✓

Sensors with IO-Link interface, coding E1

IO-Link vendor ID (HAWE)	1503 (0 x 5DF)
IO-Link website	io-link.com
IODD Finder	ioddfinder.io-link.com

Sensors with switch output, coding E2

Switch outputs 1, 2, and 3 can be configured independently of each other. Parametrisation handled at factory.

2.1.6 Switch output

Switch outputs can only be configured for sensors **E2**.

Sensors E0 and E1

Coding	Description
X00	Without switch outputs

Sensors E2

Switch outputs 1, 2, and 3 can be configured independently of each other.

The same signals can also be selected for switch outputs 1, 2 and 3, e.g. D00D50D90.

Coding (examples)	Description
D00	Level switch (N/C contact), level \geq 0%
D10	Level switch (N/C contact), level \geq 10%
D99	Level switch (N/C contact), level \geq 100%
S00	Level switch (N/O contact), level \leq 0%
S10	Level switch (N/O contact), level \leq 10%
S99	Level switch (N/O contact), level \leq 100%
T40	Temperature switch, temperature \leq 40°C
A50	Temperature switch, temperature \geq 50°C
N00	Rotation speed measurement, rotation speed > 0 rpm
N01	Rotation speed measurement, rotation speed > 100 rpm
E00	Warning or error has occurred
E01	Error has occurred

Selectable stages:

- **D:** D00 - D99 (every 10% selectable), N/C contact switching function
- **S:** S00 - S99 (every 10% selectable), N/O contact switching function
- **T:** T40 - T80 (every 10°C selectable), N/C contact switching function
- **A:** A40 - A80 (every 10°C selectable), N/O contact switching function
- **N:** N00 - N17 (every 100 rpm)

i INFORMATION

Once the configured switching threshold/condition of the switch output is met, the supply voltage for the sensors is applied to the associated output at 24 V.

HAWE eLink parameterisation software

HAWE eLink is a helpful, easy-to-use software tool for configuring, maintaining and monitoring sensors which have been integrated into the HAWE compact hydraulic power pack type INKA as an option. Can be downloaded from www.hawe.com/edocs.

A connection cable is required to link the compact hydraulic power pack and the computer with eLink. This can be purchased separately from HAWE Hydraulik.

- HAWE eLink (documentation): [HAWE eLink](#)
- HAWE eLink Setup (software): [HAWE eLink Setup](#)

2.1.7 Electrical connection

Coding	Comment
P0	Communication box, series
P1	Connection via plug connector (right)
P2	Connected via plug connector (below) (not possible for vertical installation position)
P3	Connection via plug connector (left)

2.1.8 Additional option: electric

Coding	Comment
X	No additional option
E	Interference suppression module (only possible with 3~motors)

2.1.9 Additional option: external fan

Coding	Description	Variant sensors		
		E0	E1	E2
F000	No external fan	●	●	●
F1..	<p>24 V The external fan is mounted on the side on the intermediate flange. The connecting line is connected to the interface electronics inside the communication box. External fan start can be programmed for an oil temperature between 40°C and 70°C (any 10°C increment selectable). Programmed switching hysteresis is 10°C.</p> <p>Variants:</p> <ul style="list-style-type: none"> ▪ F140: External fan starts at 40°C ▪ F150: External fan starts at 50°C ▪ F160: External fan starts at 60°C ▪ F170: External fan starts at 70°C <p>Example: in the case of type F140, the external fan starts when the oil temperature is 40°C and switches off again once the oil temperature reaches 30°C. Switch-off temperature should lie above the maximum expected ambient temperature. The external fan also switches off when oil temperature lies below the external fan's switch-on temperature for 30 minutes but switch-off temperature is not reached within this time.</p> <div style="border: 1px solid gray; padding: 5px; margin-top: 10px;"> <p>! NOTICE While the sensor is supplied with power, the external fan will keep running until one of these two switch-off criteria applies, even if the hydraulic power pack is off.</p> </div>		●	●
F10L	24 V external fan mounted on intermediate flange, with 3-m connecting line	●	●	●
F11L	1x115 V external fan mounted on intermediate flange, with 3-m connecting line	●	●	●
F12L	1x230 V external fan mounted on intermediate flange, with 3-m connecting line	●	●	●
F10S	24 V external fan mounted on intermediate flange, connected via plug connector	●	●	●
F11S	1x115 V external fan mounted on intermediate flange, connected via plug connector	●	●	●
F12S	1x230 V external fan mounted on intermediate flange, connected via plug connector	●	●	●

2.1.10 Drain hose for hydraulic fluid

Coding	Comment
G0	No hose
G3	300 mm drain hose with ball valve
G5	500 mm drain hose with ball valve
W3	300 mm drain hose with elbow and ball valve
W5	500 mm drain hose with elbow and ball valve

2.1.11 Version

Coding	Comment
0	Standard
U	prepared for UL / CSA approval, see SK 8132 000 U

2.2 Pump

- **H:** Pump elements (type MPE)
- **Z:** gear pumps
- **HD:** double pump elements (type DMPE)

2.2.1 Pump with 3-phase motor

i INFORMATION

Re the following points see Chapter 3.6, "Motor data":

- The flow rate Q_{\max} relates to the rated speed and varies depending on the load.
- At a power frequency of 60 Hz, the flow rate is approximately 1.2 times higher than that indicated here.
- The permitted pressures p_{\max} apply to a version with a 3x400 V 50 Hz/460 V 60 Hz or 3x230 V 50 Hz/265 V 60 Hz motor
- Be aware of different motor power ratings and resulting permissible maximum pressures $p_{\max} = (pV_g)_{\max} / V_g$, at other nominal voltages and power frequencies $(pV_g)_{\max}$.

Radial piston pump H

Coding	Piston diameter (mm)	Number of pump elements	Displacement volume V_g (cm ³ /rev)	INKA 14 ..-0.25 kW			INKA 14 ..-0.55 kW		
				Permissible pressure p_{\max} (bar)	Flow rate Q_{\max} (l/min)		Permissible pressure p_{\max} (bar)	Flow rate Q_{\max} (l/min)	
					50 Hz	60 Hz		50 Hz	60 Hz
H 0.27	4	3	0.19	700	0.26	0.32	700	0.25	0.31
H 0.42	5	3	0.29	560	0.39	0.48	700	0.39	0.47
H 0.64	6	3	0.42	390	0.57	0.70	700	0.56	0.69
H 0.81	7	3	0.58	280	0.79	0.96	570	0.78	0.95
H 1.10	8	3	0.75	220	1.02	1.25	440	1.01	1.22
H 1.35	9	3	0.95	170	1.30	1.58	350	1.28	1.55

i INFORMATION

see also Pump element type MPE and PE for radial piston pumps: D 5600

Radial piston pump HD

..-HD -49 /B150 -59/C120 -69/C100 ..

3rd double pump element
 2nd double pump element
 1st double pump element: [pressure range for changeover pressure](#)
 1st double pump element: [piston diameter for high pressure – low pressure](#)

piston diameter for high pressure – low pressure

Coding	Piston Ø HP – LP (mm)	Displacement volume V_g (cm ³ /rev)		Permissible pressure p_{max} (bar)		INKA 14 ..-0.25 kW				INKA 14 ..-0.55 kW								
						Flow rate Q_{max} (l/min)				Flow rate Q_{max} (l/min)								
						V_g total (LP+HP)		V_g HP	LP+HP **	HP *	LP+HP	HD	LP+HP	HD	LP+HP	HD	LP+HP	HD
											50 Hz		60 Hz		50 Hz		60 Hz	
48	4 - 8	0.25	0.05	350	700	0.34	0.07	0.42	0.08	0.33	0.07	0.41	0.08					
58	5 - 8	0.28	0.08	350	700	0.38	0.10	0.47	0.13	0.37	0.10	0.46	0.13					
68	6 - 8	0.31	0.11	350	700	0.42	0.15	0.52	0.19	0.42	0.15	0.51	0.18					
49	4 - 9	0.30	0.05	350	700	0.41	0.07	0.50	0.08	0.40	0.07	0.50	0.08					
59	5 - 9	0.33	0.08	350	700	0.45	0.10	0.55	0.13	0.44	0.10	0.54	0.13					
69	6 - 9	0.37	0.11	350	700	0.49	0.15	0.61	0.19	0.49	0.15	0.60	0.18					

ND Low pressure

HD High pressure

pressure range for changeover pressure

Coding	pressure range for changeover pressure
A	281 to 350
B	141 to 280
C	40 to 140

NOTICE

- Starting up when the system is pressurised is not permitted on the HD version.
- A horizontal (lying) installation position is not possible.

INFORMATION

The compact hydraulic power pack INKA in the HD version uses 3 double pump elements type DMPE. As a result, 3 double pump elements must always be stated. In order to get the most out of this version, the DMPE changeover pressures should be set to different values. Arranged by changeover pressure, with the largest changeover pressure first, e.g. -HD49/B150-59/C120-69/C100

see also [Double pump element type DMPE for radial piston pumps: D 5600 D](#)

i INFORMATION

* The maximum pressure of the high-pressure piston must be calculated: $p_{HP\ max} = p \times V_{g\ max} / V_{g\ HP}$

Example:

INKA..HD49/B150-59/C120-69/C100..3~400V50Hz-0.25kW

$p_{HP\ max} = p \times V_{g\ max} / V_{g\ HP} = 148.5\ bar\ cm^3 / 0.24\ cm^3 = 618.75\ bar = 615\ bar$ (rounded to the nearest 5 bar)

with hydraulic work value $p \times V_g = 148.5\ bar\ cm^3$ (for 0.25 kW)

with $V_{g\ HP}$ = sum of individual values $V_{g\ HP}$ for coding 49, 59 and 69 = $0.05+0.08+0.11 = 0.24\ cm^3$

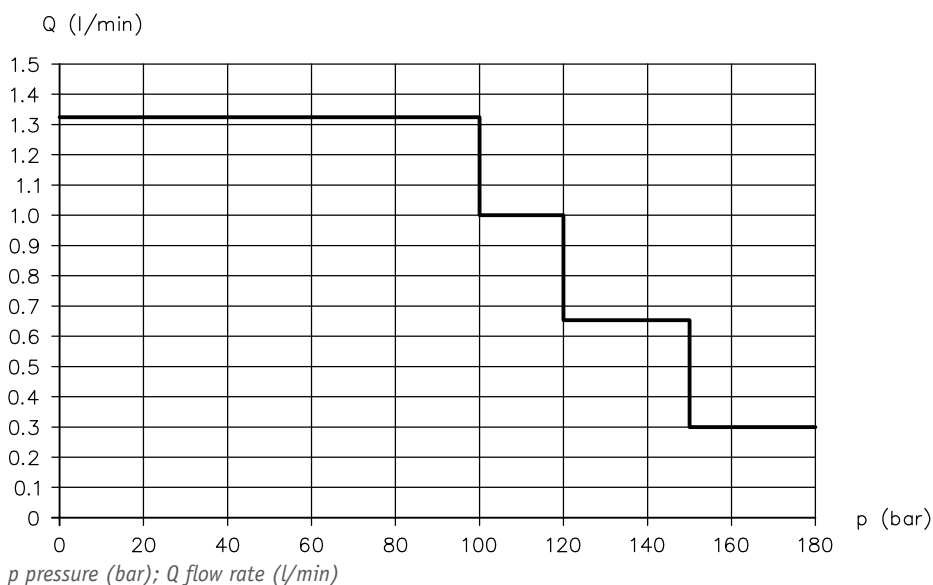

** The maximum pressure of the low-pressure piston can be taken from the type designation. This is the lowest changeover pressure (setting of the last DMPE) $p_{LP+HP\ max} = 100\ bar$

Gear pump Z

Coding	Size	Displacement volume V_g (cm ³ /rev)	INKA 14 ..-0.25 kW			INKA 14 ..-0.55 kW		
			Permissible pressure p_{max} (bar)	Flow rate Q_{max} (l/min)		Permissible pressure p_{max} (bar)	Flow rate Q_{max} (l/min)	
				50 Hz	60 Hz		50 Hz	60 Hz
Z 0.75	05	0.50	200	0.67	0.83	200	0.66	0.82
Z 1.50	05	1.00	155	1.34	1.66	200	1.32	1.63
Z 2.25	05	1.50	100	2.02	2.49	200	1.99	2.45

! NOTICE

Gear pump only possible with bottom housing cover in position 0.

2.2.2 Pump with AC motor

i INFORMATION

Re the following points see Chapter 3.6, "Motor data":

- The flow rate Q_{\max} relates to the rated speed and varies depending on the load.
- Notes on pressures p_{\max} (see Chapter 3.6, "Motor data").
- The permitted pressures p_{\max} apply to a version with a 1x230 V 50 Hz motor.
- Be aware of different motor power ratings and resulting permissible maximum pressures $p_{\max} = (pV_g)_{\max} / V_g$, at other nominal voltages and power frequencies $(pV_g)_{\max}$.
- It cannot be started up directly against the effects of pressure!

! NOTICE

- An operating capacitor is required in order to operate an AC motor.
- The operating capacitor is not included in the scope of delivery.

For operating capacitor see Chapter 3.6, "Motor data", see Chapter 6.1.9, "Selecting the operating capacitor"

Radial piston pump H

Coding	Piston diameter (mm)	Number of pump elements	Displacement volume V_g (cm ³ /rev)	INKA 14 ...-0.37 kW			
				Permissible pressure p_{\max} (bar)		Flow rate Q_{\max} (l/min)	
				1x230 V 50 Hz 1x220 V 60 Hz	1x110 V 60 Hz	50 Hz	60 Hz
H 0.27	4	3	0.19	700	550	0.25	0.30
H 0.42	5	3	0.29	460	360	0.39	0.46
H 0.64	6	3	0.42	320	250	0.56	0.67
H 0.81	7	3	0.58	230	180	0.78	0.93
H 1.10	8	3	0.75	180	140	1.01	1.20
H 1.35	9	3	0.95	140	110	1.28	1.52

Radial piston pump HD

..-HD -49 /B150 -59/C120 -69/C100 ..

3rd double pump element
 2nd double pump element
 1st double pump element: [pressure range for changeover pressure](#)
 1st double pump element: [piston diameter for high pressure – low pressure](#)

piston diameter for high pressure – low pressure

Coding	Piston Ø HP – LP (mm)	Displacement volume V_g (cm ³ /rev)		Permissible pressure p_{max} (bar)			Flow rate Q_{max} (l/min)			
		$V_{g\ total}$ (LP+HP)	$V_{g\ HP}$	LP+HP **		HP *	LP+HP	HD	LP+HP	HD
				1x230 V 50 Hz 1x220 V 60 Hz	1x110 V 60 Hz		50 Hz	60 Hz		
48	4 - 8	0.25	0.05	350	350	700	0.33	0.07	0.39	0.08
58	5 - 8	0.28	0.08	350	330	700	0.37	0.10	0.44	0.12
68	6 - 8	0.31	0.11	350	300	700	0.42	0.15	0.50	0.18
49	4 - 9	0.30	0.05	350	310	700	0.40	0.07	0.48	0.08
59	5 - 9	0.33	0.08	350	280	700	0.44	0.10	0.52	0.12
69	6 - 9	0.37	0.11	350	250	700	0.49	0.15	0.58	0.15

ND Low pressure

HD High pressure

pressure range for changeover pressure

Coding	pressure range for changeover pressure
A	281 to 350
B	141 to 280
C	40 to 140

NOTICE

- Starting up when the system is pressurised is not permitted on the HD version.
- A horizontal (lying) installation position is not possible.

INFORMATION

The compact hydraulic power pack INKA in the HD version uses 3 double pump elements type DMPE. As a result, 3 double pump elements must always be stated. In order to get the most out of this version, the DMPE changeover pressures should be set to different values. Arranged by changeover pressure, with the largest changeover pressure first, e.g. -HD49/B150-59/C120-69/C100

see also [Double pump element type DMPE for radial piston pumps: D 5600 D](#)

INFORMATION

* The maximum pressure of the high-pressure piston must be calculated: $p_{HP\ max} = p \times V_{g\ max} / V_{g\ HP}$

For example see "[Radial piston pump HD](#)" with 3-phase motor

** The maximum pressure of the low-pressure piston can be taken from the type designation. This is the lowest changeover pressure (setting of the last DMPE) $p_{LP+HP\ max} = 100\ bar$

Gear pump Z

Coding	Size	Displacement volume V_g (cm ³ /rev)	INKA 14 ...-0.37 kW			
			Permissible pressure p_{max} (bar)		Flow rate Q_{max} (l/min)	
			1x230 V 50 Hz 1x220 V 60 Hz	1x110 V 60 Hz	50 Hz	60 Hz
Z 0.75	05	0.50	200	195	0.66	0.78
Z 1.50	05	1.00	125	95	1.32	1.57
Z 2.25	05	1.50	85	65	1.99	2.36

! NOTICE

Gear pump only possible with bottom housing cover in position 0.

3 Parameters

3.1 General data

Conformity	<ul style="list-style-type: none"> ▪ Declaration of incorporation according to Machinery Directive 2006/42/EC ▪ Declaration of conformity according to Low-Voltage Directive 2014/35/EU ▪ UKCA declaration of conformity according to Electrical Equipment (Safety) Regulations 2016 No. 1101 <p>(see Compact hydraulic power pack type INKA 1: B 8132-1)</p> <p>for all coding except -U</p> <ul style="list-style-type: none"> ▪ UL conformity of stators – use of UL-approved insulation materials, motor wires according to UL Style 1330 ▪ Communication box – UL-approved plastic, UL File E41938 and UL File E121562 <p>for coding -U see SK 8132 000 U see Chapter 2.1.11, "Version"</p>
Version / Model	Hydraulic power pack with built-in electric motor (1-phase or 3-phase version) and single-circuit pump
Pump version	Valve-controlled radial piston pump or gear pump
Operating mode	<ul style="list-style-type: none"> ▪ Short period operation (S2) ▪ Periodic intermittent operation (S3)
Installation position	vertical (INKA..V) or horizontal (INKA..H) Please observe the notes on the installation position see Chapter 2.1.3, "Installation position"
Material	Housing: Aluminium Corrosion-proof up to 480 h after salt spray test ISO 9227 Communication box: Plastic
Attachment	Tightening torque: 8 Nm see Chapter 4.1, "Mounting hole pattern"
Hydraulic connection	Via screwed-on connection block according to Chapter 6.1.11, "Connection blocks"
Hydraulic fluid	Hydraulic fluid, according to DIN 51 524 Parts 2 to 3; ISO VG 10 to 68 according to DIN ISO 3448 Viscosity range: type H: 4 - 800 mm ² /s, type HD: 4 - 300 mm ² /s, type Z: 6 - 500 mm ² /s Optimal operating range: type H: 10 - 500 mm ² /s, type HD: 10 - 100 mm ² /s, type Z: 10 - 100 mm ² /s Also suitable for biologically degradable hydraulic fluids type HEES (synthetic ester) at operating temperatures up to approx. +70°C.
Cleanliness level	ISO 4406 <hr style="width: 20%; margin-left: 0;"/> 21/18/15...19/17/13
Temperatures	Environment: approx. -20 to +60°C, hydraulic fluid: -20 to +80°C, ensure the correct viscosity range. Biologically degradable hydraulic fluids: note manufacturer specifications. With consideration for the seal compatibility, not above +70°C. Start temperature: down to -40 °C is permissible (take account of the start viscosities!), as long as the steady-state temperature is at least 20 K higher during subsequent operation.
Rotation direction	Radial piston pump (type H, HD) – any Gear pump (type Z) – anticlockwise (Rotation direction only ascertainable from check of flow rate; if there is no flow rate in the 3-phase version, replace two of the three main conductors)

Speed range (min ... max)	Radial piston pump H, HD:	H:	200 to 3500 rpm 200 to 2850 rpm (optimal)
		HD:	200 to 2850 rpm
	Gear pump Z:	Z 0.75:	1000 to 3000 rpm
		Z 1.5:	800 to 2500 rpm
		Z 2.25:	800 to 2000 rpm
Visualisation	Visualisation via LEDs. No output of values. See also B 8132-1		
Breather filter	PU filter, filter fineness 10 µm Protect breather filter against moisture penetration.		
Operating elevation	< 2000 m above sea level		
Permitted water content	< 0.1%		
Transport equipment	2 transport eye-bolts on container		

3.2 Pressure and volumetric flow

Pressure	<ul style="list-style-type: none"> Pressure side (port P): depending on version and flow rate see Chapter 2.2, "Pump" Suction side (container interior): ambient air pressure. Not suitable for charging.
Start against pressure	<ul style="list-style-type: none"> The version with 3-phase motor and pump type H, Z can start against the pressure p_{max}. The version with 3-phase motor and pump type HD can only run counter to a minor pressure (circulation pressure). The version with single-phase motor cannot start against pressure.
Flow rate	see Chapter 2.2, "Pump"

3.3 Weight

Basic type	Type	
	INKA 14	10 kg
Tank	Tank size	
	1	+ 0 kg
	2	+ 0.3 kg
	3	+ 0.7 kg
Motor	3 ~ 0.25 kW	+ 0.3 kg
	3 ~ 0.55 kW	+ 2.2 kg
	1 ~ 0.37 kW	+ 1.2 kg
Pump version	Type	
	H	+ 0.3 kg
	HD	+ 1.6 kg
	Z	+ 0.5 kg
External fan	F1	+ 0.2 kg
	F10L, F10S	+ 0.25 kg
	F11L, F12L, F11S, F12S	+ 0.54 kg

For weights of the required connection blocks and valve banks, see corresponding publications, see Chapter 6.1.11, "Connection blocks".

Example 1:

INKA 141 - H 0,27.. -3 x.. 0,25

Category	Basic pump	Tank	Motor	Pump version	Total weight
Selection	INKA 14	1	3 ~ 0.25 kW	H 0.27	
Individual weights	10 kg	0 kg	0.3 kg	0.3 kg	= 10.6 kg

Example 2:

INKA 143 - Z 1,50 ... - 3 x 0,55 kW

Category	Basic pump	Tank	Motor	Pump version	Total weight
Selection	INKA 14	3	3 ~ 0.55 kW	Z 1.50	
Individual weights	10 kg	0.7 kg	2.2 kg	0.5 kg	= 13.4 kg

3.4 Characteristic lines

3.4.1 Build-up of heat

0.25 kW

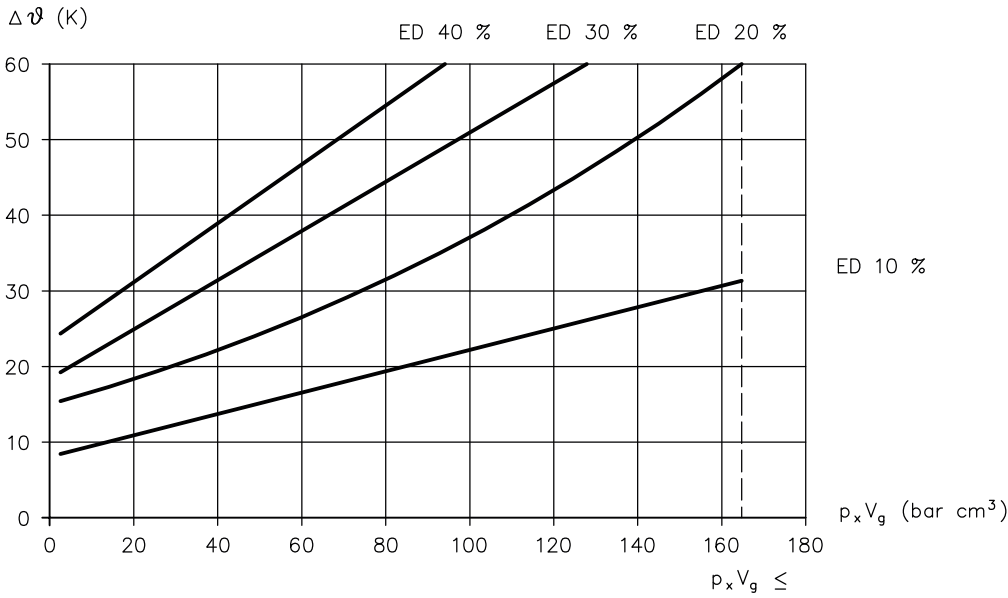

$p_x V_g$ hydraulic work value (bar cm³); $\Delta \vartheta$ steady-state excess temperature (K)
Duty cycle = Relative duty cycle

0.37 kW

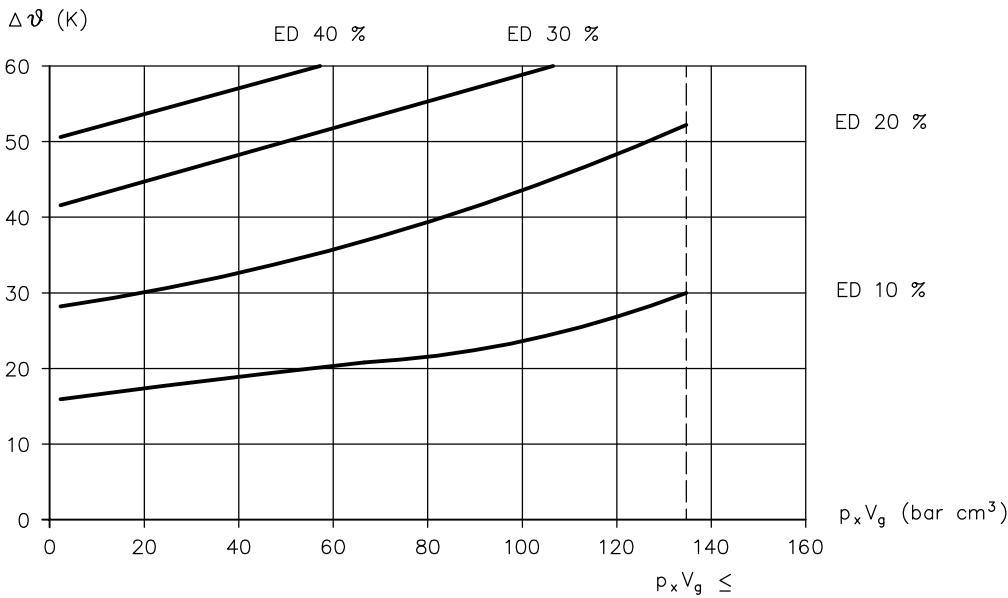

$p_x V_g$ hydraulic work value (bar cm³); $\Delta \vartheta$ steady-state excess temperature (K)
Duty cycle = Relative duty cycle

0.55 kW

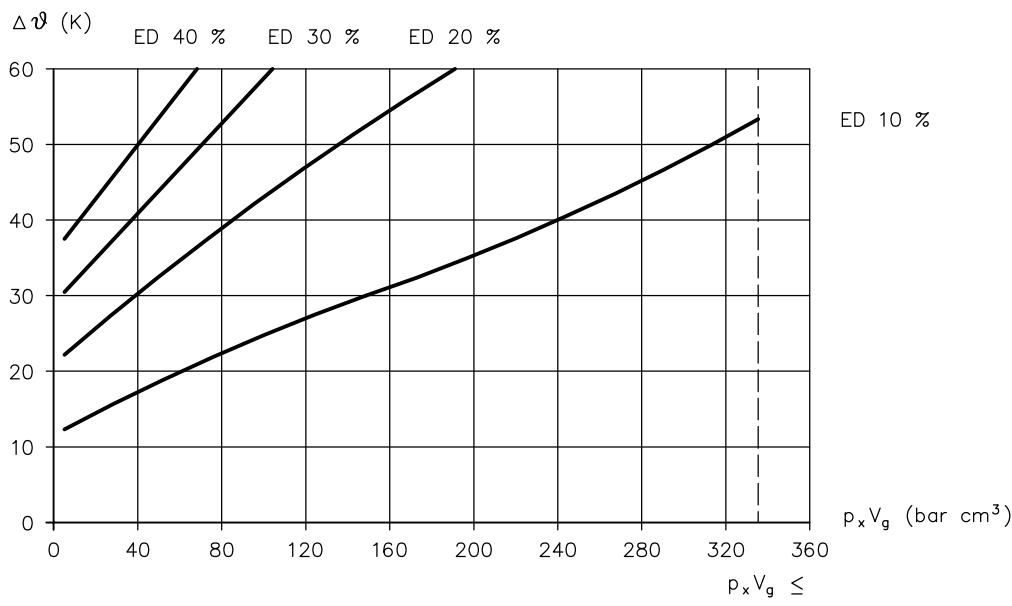

$p_x V_g$ hydraulic work value (bar cm³); $\Delta\vartheta$ steady-state excess temperature (K)
Duty cycle = Relative duty cycle

3.4.2 Running noise

Running noise H pump

Measured in acoustic measurement chamber acc. to DIN EN ISO 3744, distance sound sensor to pump (d) = 1 m

0.25 kW

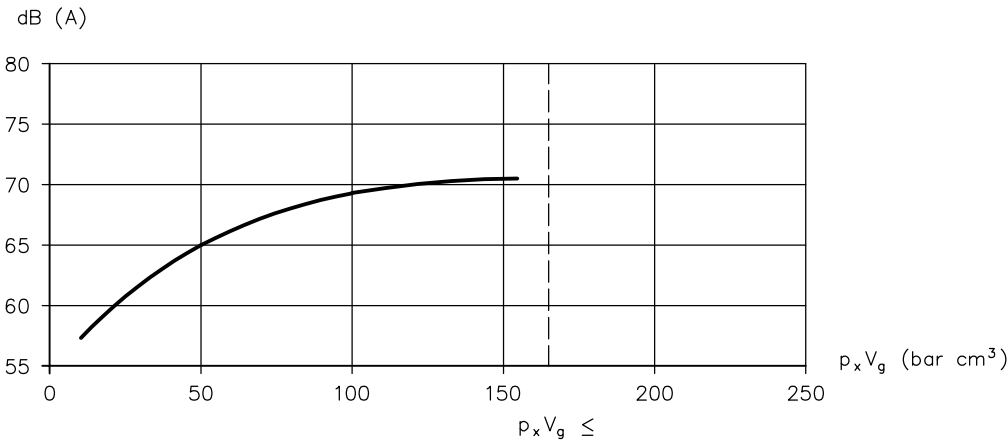

$p_x V_g$ hydraulic work value (bar cm^3); dB noise level (A)

0.37 kW

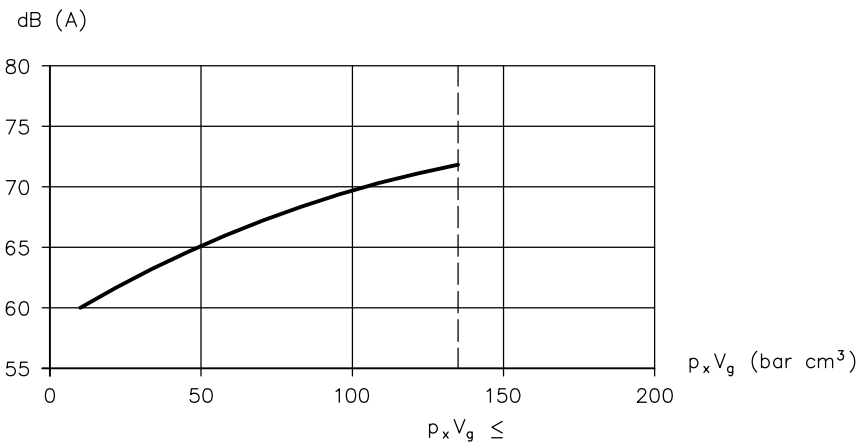

$p_x V_g$ hydraulic work value (bar cm^3); dB noise level (A)

0.55 kW

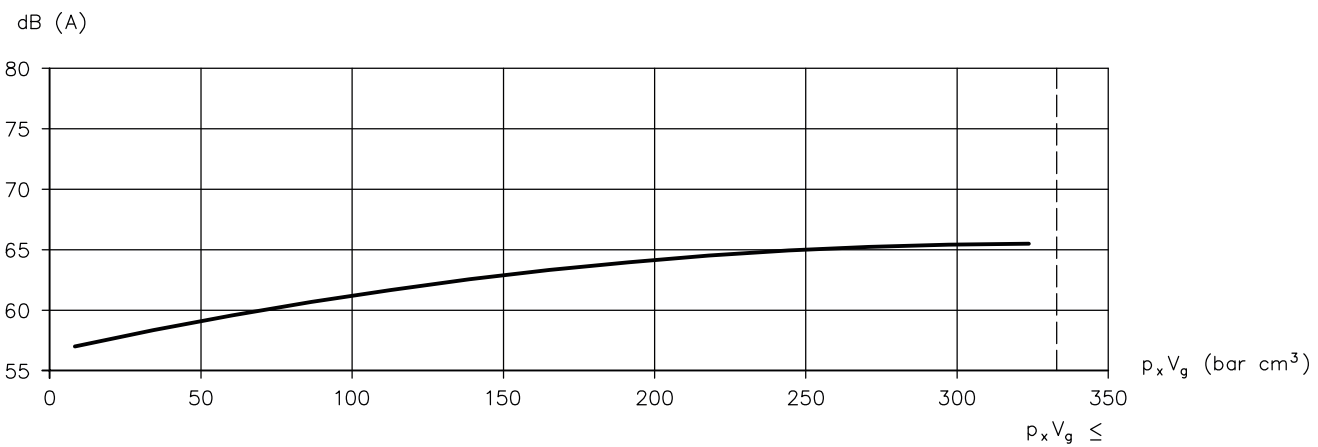

$p_x V_g$ hydraulic work value (bar cm^3); dB noise level (A)

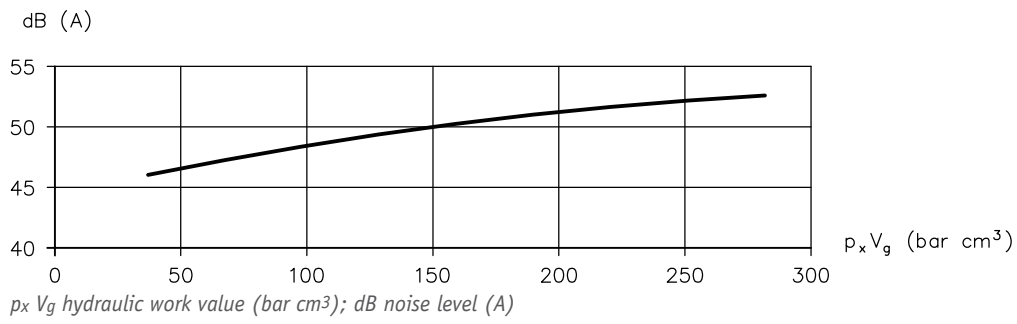
Running noise Z pump

3.5 Electrical data

The drive motor forms an enclosed, non-separable unit with the tank and pump.

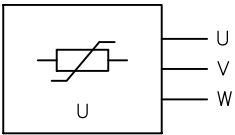
Connection	<p>part of product</p> <ul style="list-style-type: none"> For version with HARTING connector: Screw-in housing HAN 3A-EG-M20, crimp connection, pin HAN Q 5/0-M-C <p>not supplied</p> <ul style="list-style-type: none"> For version with HARTING connector: Mating connector, e.g. straight mating connector: Bushing HAN 3A-GG-M20, crimp connection, socket HAN Q 5/0-M For version with communication box: Ring cable lug M5, cable fitting M16x1.5 or M20x1.5 For version with sensors (E1 or E2): M12 plug For version with alternating current (motor 1~): capacitor (see Chapter 3.6, "Motor data")
Protection class	<p>IP 65 according to IEC 60529</p> <div style="border: 1px solid black; padding: 5px; margin-top: 10px;"> <p>i INFORMATION Protect the breather filter from moisture penetration. Protection class applies to the hydraulic power pack without additional options.</p> </div>
Protection class	<p>VDE 0100 protection class 1</p>
Insulation	<p>Designed in accordance with EN 60 664-1</p> <ul style="list-style-type: none"> For 4-wire AC voltage systems L1-L2-L3-PE (3-phase systems) with an earthed neutral point up to 500 V AC nominal phase voltage phase-phase For 3-wire AC voltage systems L1-L2-L3 (3-phase systems) without an earthed neutral point up to a nominal phase voltage of 300 V AC phase-phase For a single-phase and earthed 2-wire alternating current system L-N (alternating current or mains) up to a nominal voltage of 300 V AC.
Insulation material class	<p>F</p>
Suppressor	<p>Type RC 3 R</p>
Coding E	<ul style="list-style-type: none"> Operating voltage: 3x 575 V AC Frequency: 10 to 400 Hz max. motor power: 7.5 kW <div style="text-align: center; margin-top: 10px;">  </div>
Capacitor	<p>Capacitor is not included in the scope of delivery</p>

3.6 Motor data

i INFORMATION

- The current consumption of the motor is dependent on the load. The nominal values only apply for one operating point. In modes S2 and S3 the motor may be used at up to about 1.8 times its nominal power. The heat development which is increased here is cooled in the no-load phases or during downtimes.
- The flow and pump flow rate can be estimated on the basis of the average and maximum hydraulic work values $(pV_g)_m$ and $(pV_g)_{max}$.
- Re versions with 3-phase motors: The motor has to be ordered in star or delta circuit configuration and cannot be changed later.
- Re versions with AC motors: Actual current consumption is also dependent on the size of the operating capacitor. The operating capacitor is not included in the scope of delivery.
For operating capacitor specifications: 1x230 V 50 Hz - ... μ F / 400 V DB.
- Voltage tolerances: $\pm 10\%$ (IEC 60038), at 3x460/265 V 60 Hz $\pm 5\%$. It can be operated at undervoltage.
- Notes on the selection and composition of the product: see Chapter 6.1, "Planning information"

3-phase motor

Type	Nominal voltage and power frequency U_N (V), f (Hz)	Nominal power P_N (kW)	Rated speed n_N (rpm)	Nominal current I_N (A)	Starting current ratio I_A / I_N	Power factor $\cos \varphi$	Hydraulic work value $(pV_g)_{max}$ (bar cm^3 /rpm)		
							Pump		
							H	HD	Z
INKA 14 ..-0.25 kW	3~400 V 50 Hz / 460 V 60 Hz	0.25	1400 / 1730	0.70 / 0.67	4.2 / 5.1	0.75 / 0.65	165	148.5	156.75
	3~230 V 50 Hz / 265 V 60 Hz	0.25	1400 / 1730	1.21 / 1.16	4.2 / 5.1	0.75 / 0.65	165	148.5	156.75
	3~200 V 50 Hz / 3~220 V 60 Hz	0.25	1400 / 1730	1.4 / 1.3	4.2 / 5.1	0.75 / 0.65	165	148.5	156.75
INKA 14 ..-0.55 kW	3~400 V 50 Hz / 460 V 60 Hz	0.55	1380 / 1700	1.41 / 1.37	4.4 / 5.4	0.78 / 0.69	332.5	299.25	315.88
	3~230 V 50 Hz / 265 V 60 Hz	0.55	1380 / 1700	2.40 / 2.37	4.4 / 5.4	0.78 / 0.69	332.5	299.25	315.88
	3~200 V 50 Hz / 3~220 V 60 Hz	0.55	1380 / 1700	2.8 / 1.75	4.4 / 5.4	0.78 / 0.69	332.5	299.25	315.88

AC motor

Type	Nominal voltage and power frequency U_N (V), f (Hz)	Nominal power P_N (kW)	Rated speed n_N (rpm)	Nominal current I_N (A)	Starting current ratio I_A / I_N	Power factor $\cos \varphi$	Hydraulic work value $(pV_g)_{max}$ (bar cm^3)			Recommended operating capacitor C_B (μ F)
							Pump			
							H	HD	Z	
INKA 14 ..-0.37 kW	1~230 V 50 Hz	0.37	1380	2.69	2.5	0.95	135	121.5	128.25	12
	1~220 V 60 Hz	0.37	1640	2.7	2.5	0.95	135	121.5	128.25	12
	1~110 V 60 Hz	0.37	1640	5.7	2.5	0.95	135	121.5	128.25	50

3.6.1 Current consumption characteristic lines

i INFORMATION

For 230 V 50 Hz (265 V 60 Hz), the motor current values must be multiplied by $\sqrt{3}$.

3 x 400 V 50 Hz 0.25 kW

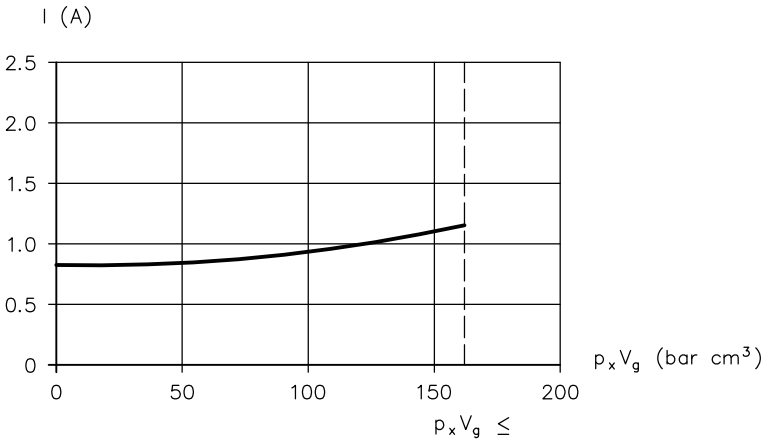

$p_x V_g$ hydraulic work value (bar cm^3); I current consumption (A)

3 x 400 V 50 Hz 0.37 kW

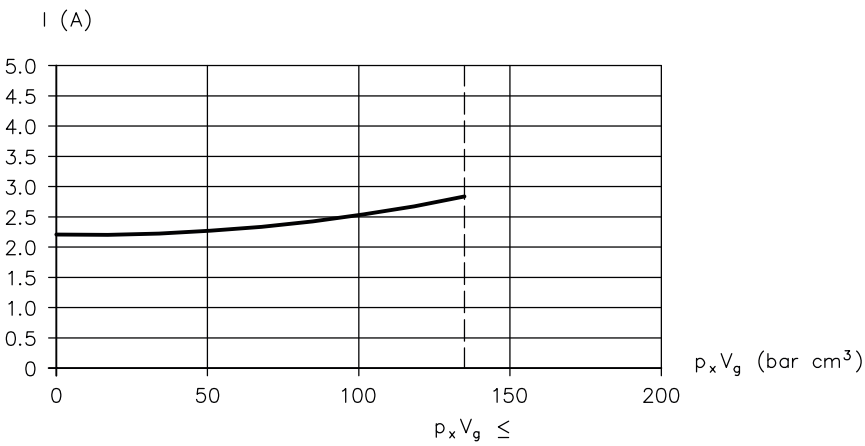

$p_x V_g$ hydraulic work value (bar cm^3); I current consumption (A)

1 x 230 V 50 Hz 0.55 kW

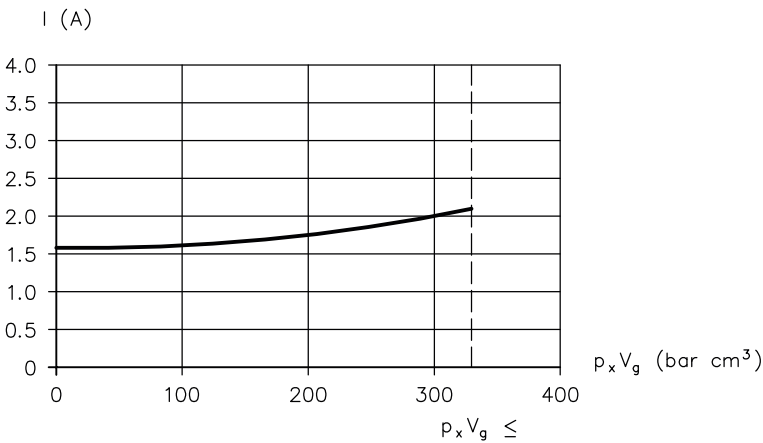

$p_x V_g$ hydraulic work value (bar cm^3); I current consumption (A)

3.7 Additional options

3.7.1 Additional option: sensor system

Pin assignment sensors E1

Pin		Function
1	L+	24 V DC for sensor
2	P 24	24 V DC for external fan
3	L-	GND for sensor
4	C/Q	I/O link data line
5	N24	GND for external fan

Pin assignment sensors E2

Pin		Function
1	L+	+24 V DC for sensor and external fan
2		Switch output 1
3	L-	GND for sensor and external fan
4		Switch output 2
5		Switch output 3

NOTICE

Power supply for sensors E1 and E2

- Supply voltage 18 to 30 V
- Maximum current 3 A

3.7.2 External fan

	F1., F10L, F10S	F11L, F11S	F12L, F12S
Voltage	24 V DC	1~115 V	1~230 V
Frequency	--	50 / 60 Hz	50 / 60 Hz
Current consumption	210 mA	230 / 200 mA	115 / 100 mA
Power consumption	5.0 W	19 / 17 W	19 / 17 W
Rotation speed	2800 rpm	2650 / 3100 rpm	2650 / 3100 rpm
Max. flow rate	170 m ³ /h	152 / 180 m ³ /h	152 / 180 m ³ /h
Protection class	IP 68	IP 68	IP 68
Protection class	III	I	I
Noise level	49 dB(A)	40 / 45 dB(A)	40 / 45 dB(A)
Approval	VDE, CSA, UL, CE	VDE, CSA, UL, CE	VDE, CSA, UL, CE

4 Dimensions

All dimensions in mm, subject to change.

4.1 Mounting hole pattern

Horizontal version coding **H**

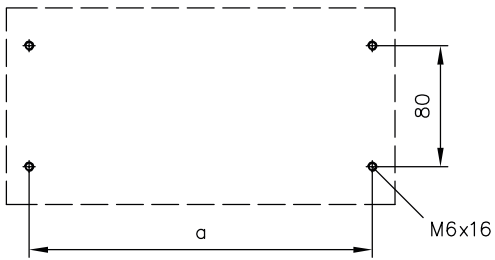

Vertical version coding **V**

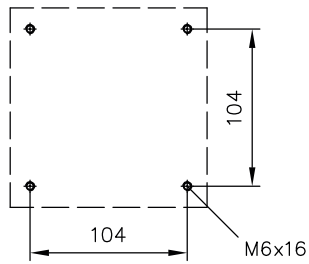

Coding tank size	a
1	227
2	272
3	322

4.2.2 Horizontal version

Tank size 1

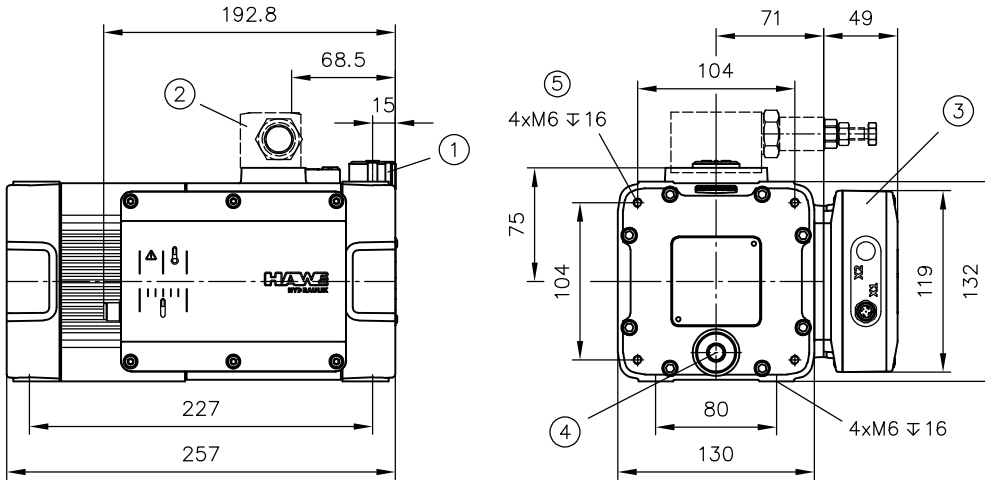

- 1 Filler port and breather filter (hydraulic fluid)
Filling G 1/2
Breather filter (10 µm)
- 2 Connection base with connection block; example: Type AB 1 K
- 3 Communication box
- 4 Hydraulic fluid drain G 1/2
Drain hose
- 5 Mounting thread (on both covers)

Tank size 2

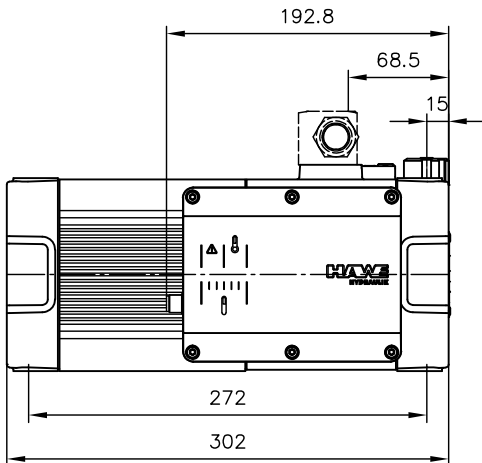

Tank size 3

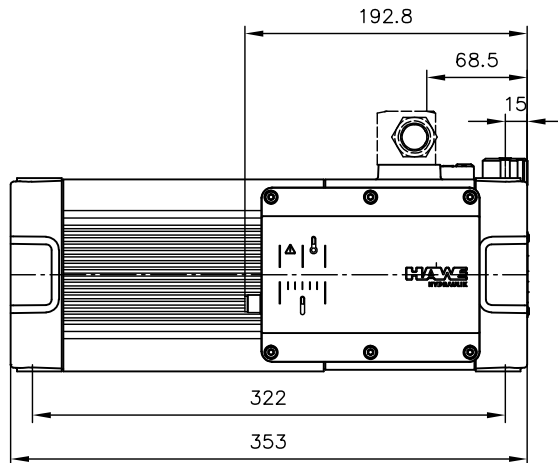

4.2.3 Additional options

Sensors on communication box

Coding E0

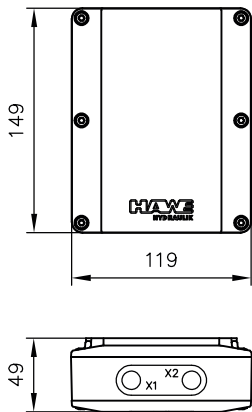

Coding E1

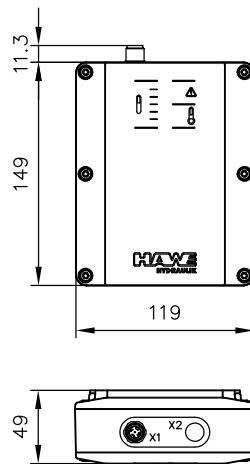

Coding E2

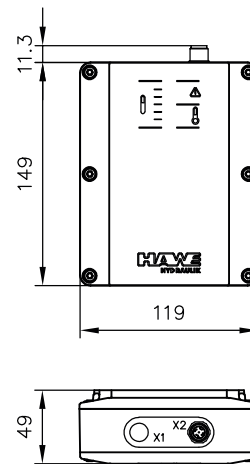

Electrical additional options

Coding X

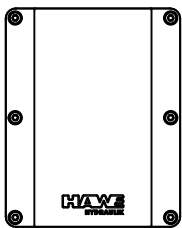

Coding E

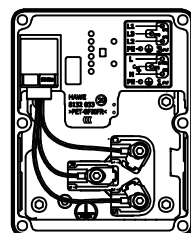
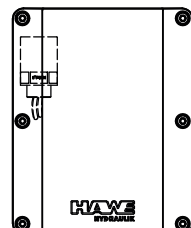

External fan

Minimum wall clearance

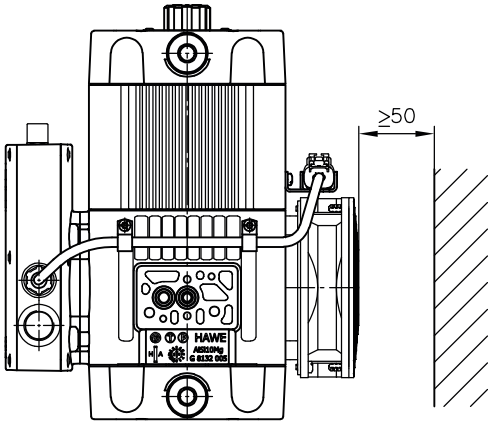

i INFORMATION

- F10L, F10S with external fan 24 V
- F11L, F11S with external fan 1~115 V
- F12L, F12S with external fan 1~230 V

see Chapter 2.1.9, "Additional option: external fan"

F1..

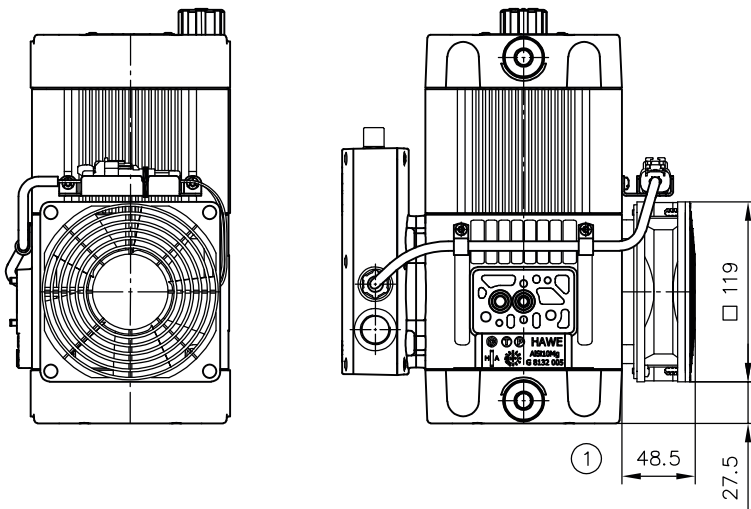

1 with external fan 24 V

F10L, F11L, F12L

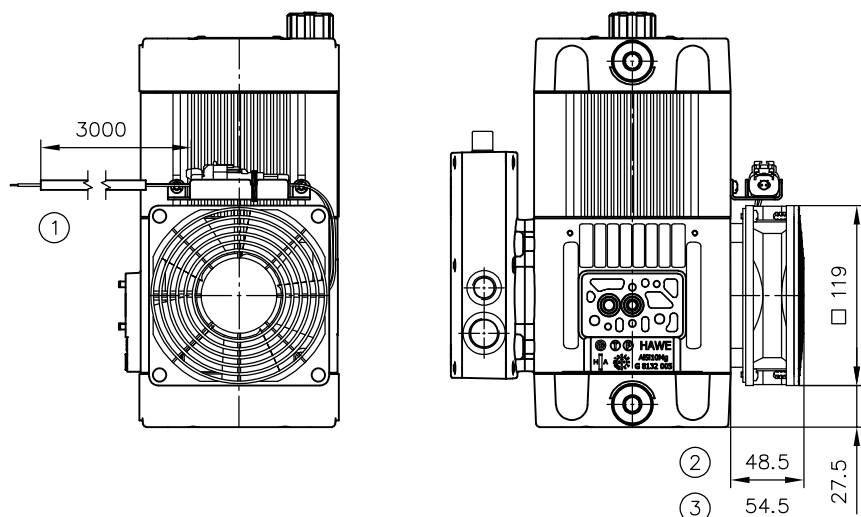

- 1 Connecting line
- 2 with external fan 24 V
- 3 with external fan 1~115; 1~230 V

F10S, F11S, F12S

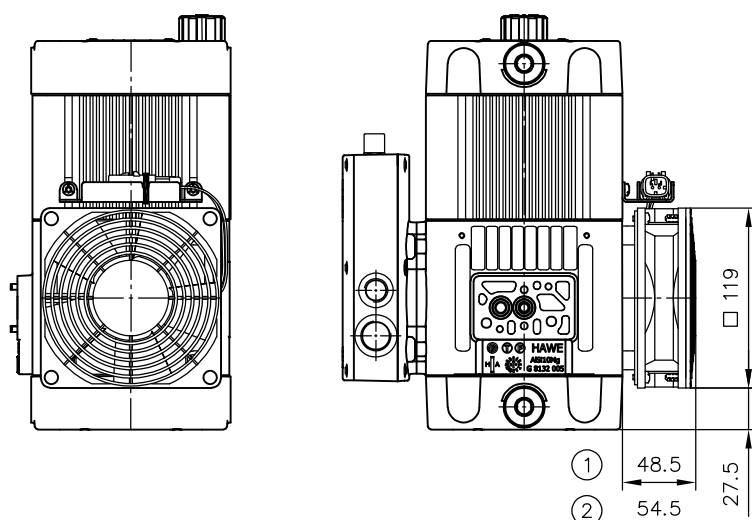

- 1 with external fan 24 V
- 2 with external fan 1~115; 1~230 V

Plug connector for external fan

F10S

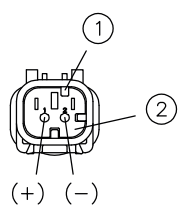

- 1 Coding "Key B" for 24 V DC
Plug connector 776428-2
- 2 Colour of connector housing: grey

F11S, F12S

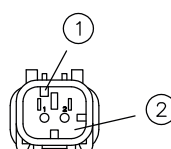

- 1 Coding "Key A" for 1~230 V/1~110 V
Plug connector 776428-1
- 2 Colour of connector housing: red

see Chapter 4.3.2, "Electrical connections"

4.3 Connections

4.3.1 Hydraulic connections

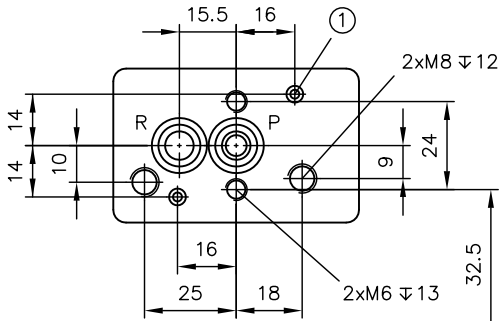

1 Centring pin $\varnothing 4$ mm

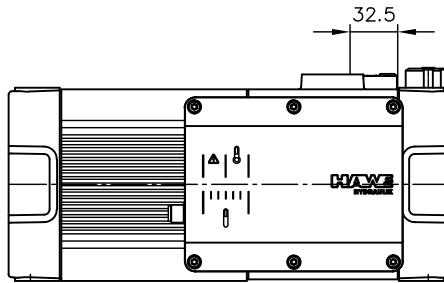

Hole for self-made connection block

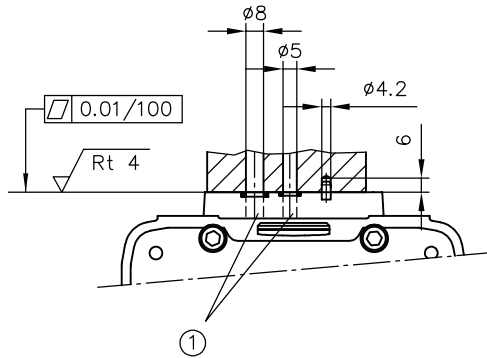

1 Sealing of connections:
P, R = 8x2 NBR 90 Sh

Example: connection block C 5, C 6

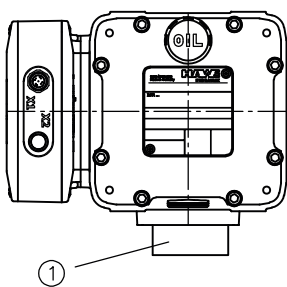
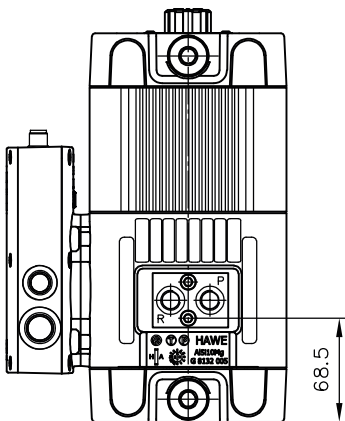

1 Connection block type C 5, C 6

i INFORMATION

For further information see AB blocks: D 6905 AB, B blocks: D 6905 B, C blocks: D 6905 C. see Chapter 6.1.11, "Connection blocks"

Drain hose for hydraulic fluid

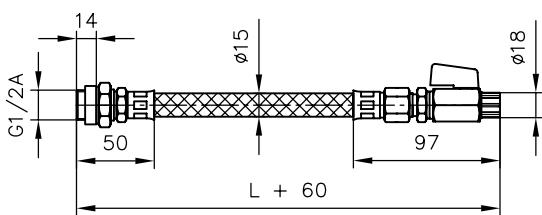

Coding	L
G3	300
G5	500

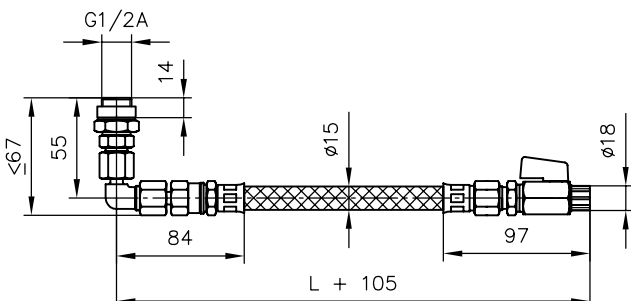

Coding	L
W3	300
W5	500

4.3.2 Electrical connections

Connected via communication box

Coding P0

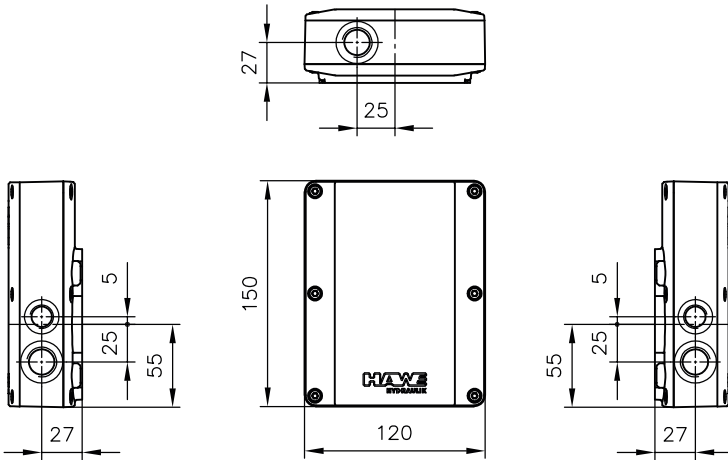

Connection for 3-phase motor

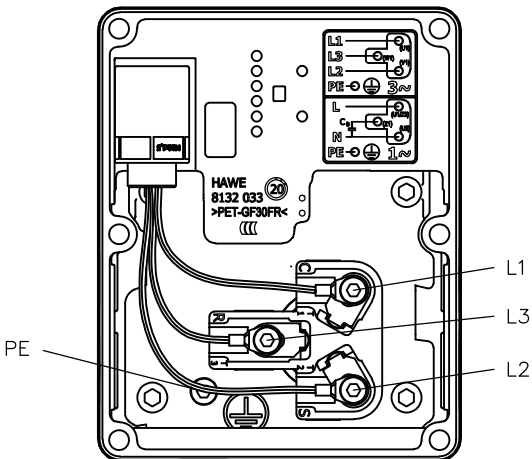

	Y *	Δ
L1	U1	U1/W2
L2	V1	V1/U2
L3	W1	W1/V2
PE	⊕	⊕

* U2, V2, W2 connected at factory

Connection for AC motor

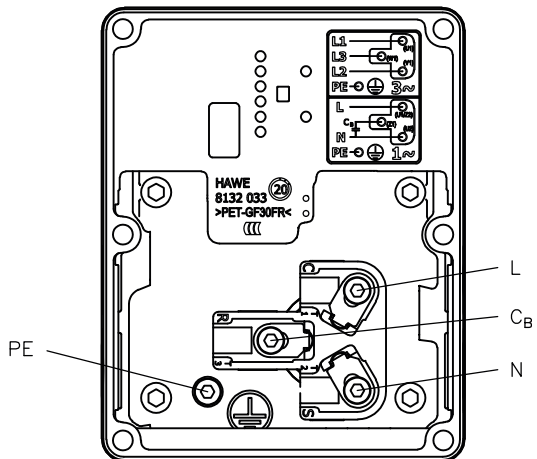

L	U1/Z2
N	U2
C _B	Z1/U2
PE	⊕

Connected via connectors

Coding P1

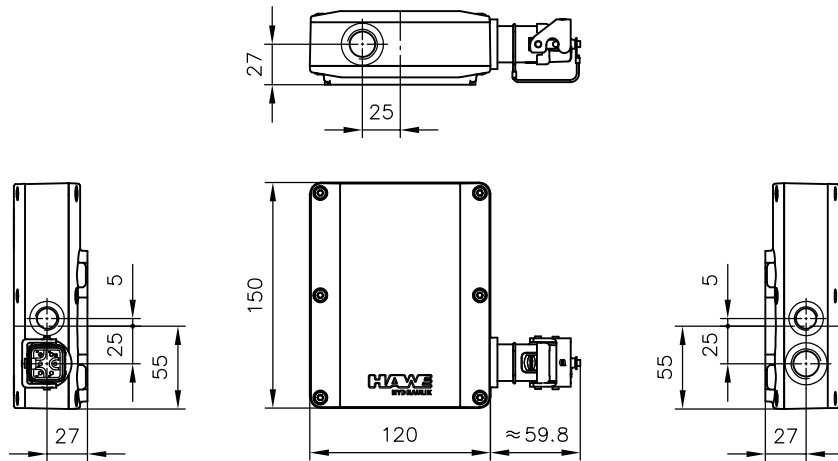

Coding P2

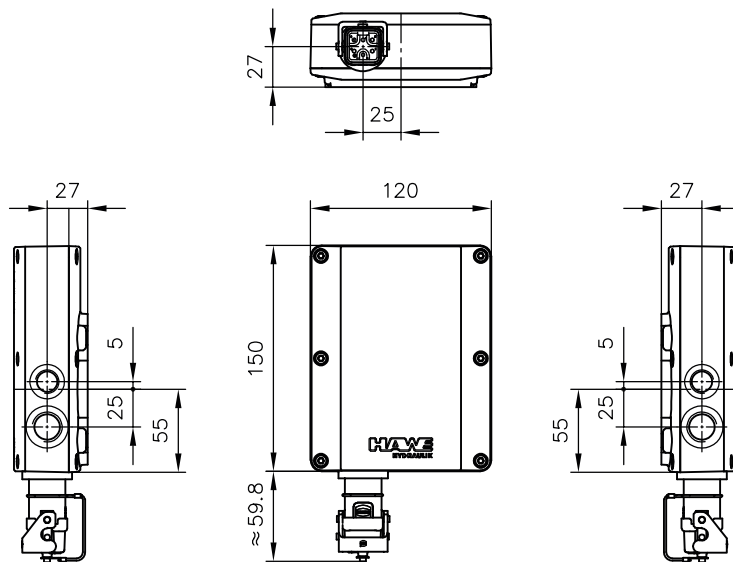

Coding P3

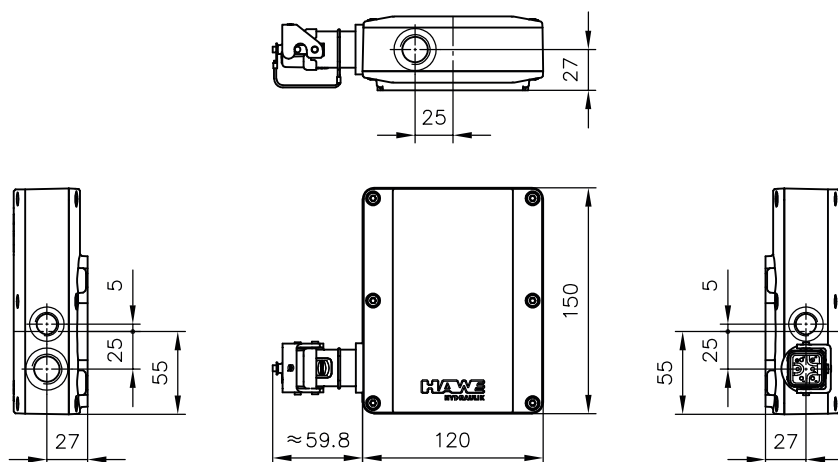

Connection for 3-phase motor

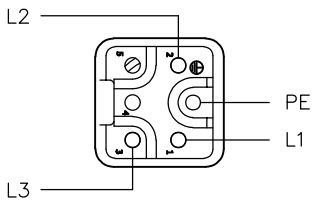

Connection for AC motor

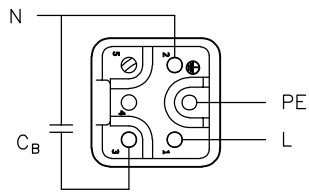

5**Installation, operation and maintenance information****!** NOTICE**Reference to other document**

[Assembly instructions for compact hydraulic power pack type INKA 1: B 8132-1](#)

Available for this product: assembly instructions with notes on

- intended use,
- operating and maintenance,
- Assembly information

6 Other information

6.1 Planning information

i INFORMATION

The procedure for the selection and design of compact hydraulic power packs with a valve attachment is described below. In order to find the ideal solution, several iterative steps generally have to be carried out.

6.1.1 Drawing up function diagram

The required or desired (hydraulically activated) functions form the basis for the function diagram.

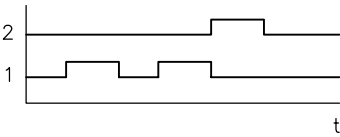

6.1.2 Determining pressures and flow rates

1. Dimension and select actuators based on the reaction forces that occur
2. Calculate flow rates based on the desired velocity profiles

i NOTICE

Observe the reset times of spring-loaded clamping cylinders when dimensioning pipelines or hose lines as well as the valves

In the case of time-linked clamping devices, the release of spring-loaded clamping cylinders may have a greater influence over the time interval than clamping. The return stroke times are determined exclusively by the forces of the reset springs. They drive the cylinder pistons ahead, against the flow resistance from directional valves and pipelines.

3. Calculate necessary operating pressures
4. Determine maximum necessary pump flow rate Q (l/min)
5. Determine system operating pressure p_{max} (bar)

Q - flow rate

p - pressure

A - Area

v - Velocity

F - Force

$$Q \text{ (l/min)} = 0,06 \cdot A \text{ (mm}^2\text{)} \cdot v \text{ (m/s)}$$

$$p \text{ (bar)} = \frac{10 \cdot F \text{ (N)}}{A \text{ (mm}^2\text{)}}$$

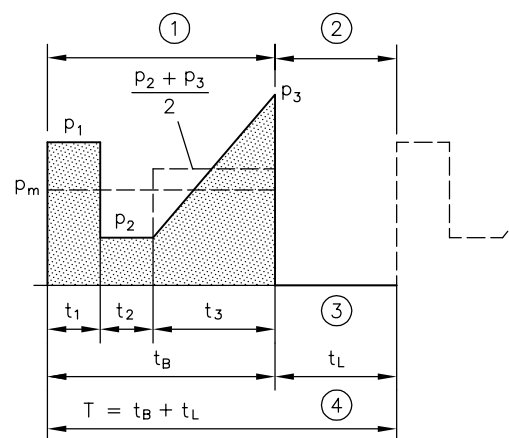

- 1 Loaded period t_B
- 2 No-load period t_L
- 3 No load
- 4 One working cycle

6.1.3 Creating a hydraulic circuit diagram

Selection criteria

- Single circuit system
- Accumulator charging mode
- Use of an accumulator to provide short-term support for the pump flow rate

6.1.4 Drawing up a time/load diagram on the basis of a function diagram

Deriving the mode for the compact hydraulic power pack

- ▶ Calculation of the relative duty cycle %ED
- ▶ S2 – Short period operation
- ▶ S3 – Periodic intermittent operation

6.1.5 Selecting the compact hydraulic power pack

1. Select basic type based on power supply

- 3-phase power
- Alternating current

2. Select motor

- Voltage tolerances: $\pm 10\%$ (IEC 60038), at 3x460/265 V 60 Hz $\pm 5\%$
- It can be operated at undervoltage. Bear in mind that this will involve performance restrictions.

$$p_{\max \text{ red}} = p_{\max} * k$$

p_{\max} (bar) – max. operating pressure in accordance with the selection tables

$p_{\max \text{ red}}$ (bar) – reduced max. available operating pressure

* k – correction factor from the diagram

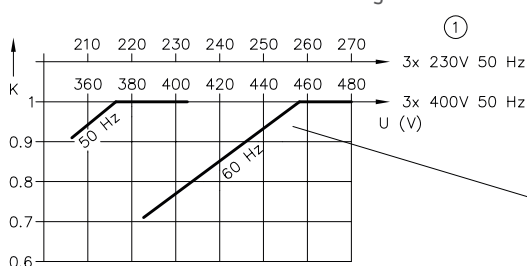

U supply voltage (V); K correction factor

1 Motor design



INFORMATION

Pump flow rate 1.2 x greater than with 50 Hz operation.

3. Select pump type (radial piston pump, gear pump)

4. Select the key figure for the pump flow rate, taking into account the maximum permissible pressure

5. Determine basic type based on motor size

6. Estimate noise level on the basis of parameters

6.1.6 Calculating the hydraulic work value

1. Calculate mean pressure
2. Calculate mean hydraulic work value (average pressure x flow rate)
3. Calculate maximum hydraulic work value (max. operating pressure x flow rate)

Calculation

p_m (bar) = calculated average pressure per cycle during the load time

$$t_B = t_1 + t_2 + t_3 + \dots$$

$$p_m = \frac{1}{t_B} \left(p_1 \cdot t_1 + p_2 \cdot t_2 + \frac{p_2 + p_3}{2} \cdot t_3 + \dots \right)$$

$p_m V_g$ = average hydraulic work value

V_g = geometric displacement volume

$$(pV_g)_{\max} (\text{bar cm}^3) = p_{\max} * V_g$$

6.1.7 Determining the steady-state temperature

i INFORMATION

Observe the maximum permissible temperature of the hydraulic fluid of 80°C!

For further restrictions regarding other hydraulic fluids see Chapter 3.1, "General data"

Calculation

$$\vartheta_{\text{oil B}} = \Delta \vartheta_{\text{B}} + \vartheta_{\text{U}}$$

$\vartheta_{\text{oil B}}$ (°C)	Steady-state temperature of the hydraulic fluid
$\Delta \vartheta_{\text{B}}$ (K)	Steady-state temperature (estimation from the characteristic lines to determine the excess temperature)
ϑ_{U} (K)	Ambient temperature at the place of installation

For an approximate check of the steady-state temperature of the hydraulic fluid, the two most important data are generally sufficient:

- average hydraulic work of the pump $(pV_g)_m$ and
- relative load duration per working cycle (% duty cycle).

Other influencing factors are

- Pressure run during the load phase (average pressure)
- Time share of the no-load phase
- Additional throttle losses over and above normal flow resistances (approx. 30%) from valves and lines are only to be taken into account if they take effect over a longer share of time within a working cycle (load phase). For instance, this includes work against the pressure-limiting valve (loss = 100%)

see also Chapter 3.4, "Characteristic lines"

$$\text{Relative duty cycle \% ED} = \frac{t_B}{t_B + t_L} \cdot 100$$

t_B Load time

t_L No-load time

i INFORMATION

Lower steady-state temperatures with larger tank.

Lower steady-state temperatures with external fan.

6.1.8 Determining the maximum current consumption

Determine current consumption from the electrical data

- ▶ see Chapter 3.5, "Electrical data"

Set motor protection circuit

- ▶ Set motor protection circuit to 0.85 to 0.9 times the motor current (I_M), see operating instructions B 8132-1

6.1.9 Selecting the operating capacitor

! NOTICE

- An operating capacitor is required in order to operate an AC motor.
- The operating capacitor is not included in the scope of delivery.

- ▶ The values listed in the table, [see Chapter 3.6, "Motor data"](#), ensure that the specified pressures are achieved.
- ▶ Where the utilisation is < 75% of the maximum possible hydraulic work value (pV_g): use an approx. 30% smaller capacitor to reduce the power losses.
- ▶ Select capacitor according to motor voltage:

Motor voltage	Rated voltage
1x230 V 50 Hz	400 V DB

6.1.10 Setting the pump after-run

If the compact hydraulic power pack is wired directly to the hydraulic cylinder, e.g. in the circuit for clamping devices (B-type connection blocks), and if a pressure switch causes it to cut out once the set pressure has been reached, a certain increase in pressure still takes place as a result of the after-run action of the pump motor.

The level of this additional rise in pressure is dependent on the pressure setting, on the consumer volume and on the pump flow rate.

If you wish to prevent these pressure rises, the setting for the pressure-limiting valve has to be adjusted in line with the switch-off point on the pressure switch. As a result, the subsequent delivery from the pump is discharged via the pressure-limiting valve.

The adjustment of the after-run should be carried out as follows:

1. Open the pressure-limiting valve fully.
2. Set the pressure switch to the highest value (by turning the adjusting screw clockwise as far as it will go).
3. Switch on the pump (with a consumer and pressure gauge connected) and turn up the pressure-limiting valve until the pressure gauge shows the required end operating pressure.
4. Turn the pressure switch in the opposite direction until the pump is switched off at the pressure value set.
[see Chapter 3, "Parameters"](#)
5. Lock the pressure-limiting valve and the pressure switches.

The rise in pressure due to the after-run can also be avoided by using an accumulator or additional volume in the load line.

If the hydraulic power pack is used to full capacity, i.e. the pressure setting is close to the maximum permissible pressure, then practically no after-run occurs because the pump comes to a standstill almost immediately after being switched off.
[see Chapter 2, "Available versions"](#)

6.1.11 Connection blocks

A connection block is necessary to make a compact hydraulic power pack ready for a hydraulic connection.

i INFORMATION

When selecting one, take note of the specifications for the connection block and mounted directional valves.

When setting the pressure-limiting valve on the connection block, take note of the pump's and valve mounting's maximum permitted pressure.

Type	Description	Publication
AB, AL	<p>For single-circuit pumps with a pressure-limiting valve and the possibility of direct mounting of directional valve banks</p> <p>Optional:</p> <ul style="list-style-type: none"> ▪ Pressure filter or return line filter ▪ Idle circulation valve ▪ Accumulator charging valve ▪ Proportional pressure-limiting valve <div style="border: 1px solid #ccc; padding: 5px; margin-top: 10px;"> <p>i INFORMATION</p> <p>When using the electrical port P1: for geometric reasons, connection block AB 1 can only be used together with an additional spacer plate.</p> </div>	<p>D 6905 AB SK 6905 AD</p>
AB..X	<p>For single-circuit pumps with a component-approved pressure-limiting valve and the possibility of direct mounting of directional valve banks (for use in accumulator systems)</p> <p>Optional:</p> <ul style="list-style-type: none"> ▪ Pressure filter or return line filter ▪ Idle circulation valve 	<p>D 6905 AB SK 6905 AD TÜV</p>
B	<p>For single-circuit pumps for the activation of single-acting cylinders with a pressure-limiting valve and drain valve</p> <p>Optional:</p> <ul style="list-style-type: none"> ▪ Throttle valve 	D 6905 B
C	<p>For single-circuit pumps with connections P and R for direct piping</p>	D 6905 C

6.1.12 Planning directional valve banks

i INFORMATION

The direct mounting of valve banks with directional valves on connection blocks enables a compact hydraulic unit to be assembled without the need for additional piping.

This applies to all types except type **C**.

! NOTICE

Maximum number of valves that can be installed: 6

Type	Description	p_{\max} (bar)	Publication
VB	Valve bank (directional seated valve)	700	D 7302
BWN, BWH	Valve bank (directional seated valve)	450	D 7470 B/1
SWR, SWS	Valve bank (directional spool valve)	315	D 7951
BA	Valve bank for the combination of different directional valves with connection pattern NG 6 in accordance with DIN 24 340-A6	400	D 7788
BVH	Valve bank (directional seated valve)	400	D 7788 BV
NBVP	Directional seated valve	400	D 7765 N
ROLV	Directional seated valve	400	D 8144
NSWP	Directional spool valve	315	D 7451 N
NSMD	Clamping module (Directional spool valve with a pressure reducing valve and acknowledge function)	120	D 7787
NZP	Intermediate plates with connection pattern NG 6 in accordance with DIN 24 340-A6	400	D 7788 Z

References

Compact hydraulic power packs

- Compact hydraulic power pack type KA and KAW size 2: D 8010
- Compact hydraulic power packs type KA size 4: D 8010-4
- Compact hydraulic power pack type MPN and MPNW: D 7207
- Compact hydraulic power pack type HK 3: D 7600-3
- Compact hydraulic power pack type HKL and HKLW: D 7600-3L
- Compact hydraulic power pack type HK 4: D 7600-4
- Compact hydraulic power pack type NPC: D 7940
- Mini hydraulic power pack type H 300, 350: D 6344
- Mini hydraulic power pack type H 400, 410, 440: D 6345
- Mini hydraulic power pack type HR 050: D 6014
- Micro hydraulic power pack type HR 080: D 6342
- Mini hydraulic power pack type HR 120: D 6343
- Servo hydraulic power pack type HS 120: D 6347
- Mini hydraulic power pack type A: D 6025

Connection blocks

- Connection blocks for single-circuit pump types AB, AL: D 6905 AB
- Connection blocks type B for hydraulic power packs: D 6905 B
- Connection blocks type C: D 6905 C

Valves and valve banks

- Valve bank (directional seated valve) type VB: D 7302
- Valve bank (directional seated valve) type BWN and BWH: D 7470 B/1
- Directional spool valve type SWPN: D 7451 AT
- Directional spool valve bank type SWS: D 7951
- Valve bank (nominal size 6) type BA: D 7788
- Valve bank (directional seated valve) type BVH: D 7788 BV
- Directional seated valve type NBVP 16: D 7765 N
- Directional seated valve type ROLV: D 8144
- Directional spool valve type NSWP 2: D 7451 N
- Clamping module type NSMD: D 7787
- Intermediate plate type NZP: D 7788 Z

Attached components

- Fitting type X 84: D 7077
- Diaphragm accumulator type AC: D 7969
- Miniature accumulator type AC: D 7571

