

Pressure-limiting valve type MV., SV., DMV..

Product documentation



Operating pressure p_{\max} :

700 bar

Flow rate Q_{\max} :

160 l/min



© by HAWE Hydraulik SE.

The reproduction and distribution of this document, as well as the use and communication of its contents to others without explicit authorization, is prohibited.

Offenders will be held liable for the payment of damages.

All rights reserved in the event of patent or utility model applications.

Brand names, product names and trademarks are not specifically indicated. In particular with regard to registered and protected names and trademarks, usage is subject to legal provisions.

HAWE Hydraulik respects these legal provisions in all cases.

HAWE Hydraulik cannot provide individual guarantees that the stated circuits or procedures (including in part) are not subject to the intellectual property rights of third parties.

Printing date / document generated on: 2024-04-04

Table of Contents

1	Overview Pressure-limiting valve type MV., SV., DMV.....	4
2	Available versions.....	5
2.1	Basic type and size.....	5
2.2	Pressure range and flow rate.....	7
2.3	Adjustment.....	8
2.4	Damping.....	8
3	Parameters.....	9
3.1	General data.....	9
3.2	Weight.....	10
3.3	Characteristic lines.....	11
4	Dimensions.....	13
4.1	MV.....	13
4.2	MVS.....	14
4.3	MVE.....	16
4.4	MVP.....	19
4.5	SV.....	22
4.6	DMV.....	22
4.7	DMVN.....	23
4.8	MVT.....	24
4.9	MVCS.....	24
4.10	SVC.....	25
5	Installation, operation and maintenance information.....	26
5.1	Intended use.....	26
5.2	Assembly information.....	26
5.3	Operating instructions.....	26
5.4	Maintenance information.....	27
6	Other information.....	28
6.1	Setting instructions.....	28

1 Overview Pressure-limiting valve type MV., SV., DMV..

Pressure-limiting valves are a type of pressure valve. They safeguard the system against excessive system pressure or limit the operating pressure.

Sequence valves generate a constant pressure difference between the inlet and outlet flow.

The types MV., SV., DMV.. are directly controlled valves that are damped as standard.

Features and advantages

- Operating pressures up to 700 bar
- Various adjustment options
- Numerous configurations

Intended applications

- General hydraulic systems
- Test benches
- Hydraulic tools



Type MV, MVS, MVCS



Type MVE



Type MVP



Type SV, SVC



Type DMV, DMVN

Types

- **Pressure-limiting valve**
Safeguards against exceeding the maximum permissible (for the system) pressure (safety valve) or limits operating pressures.
- **Sequence valve**
Generates a constant pressure difference between the inlet and outlet of the flow rate.
- **Undamped pressure-limiting valve**
For particular operating conditions, e.g. for preventing gradual pressure increases in blocked cylinder chambers when the temperature increases or with forced creeping piston movement as a result of external forces. Very small difference between opening and shut-off pressure.

i INFORMATION

The pressure-limiting valves type MV., SV., DMV.. are not suitable for safeguarding pressure equipment pursuant to the Pressure Equipment Directive 2014/68/EU. The versions according to [D 7000 TUV](#), [D 7710 TUV](#) are available for this.

2 Available versions

Ordering example

MVP 4	A			-650
MV 53	B	R	X	
DMV 4	B/C			-300/200

Pressure setting

2.4 "Damping"

2.3 "Adjustment"

2.2 "Pressure range and flow rate"

2.1 "Basic type and size"

2.1 Basic type and size

Type	Size	Description	Ports (ISO 228-1)	Available pressure ranges Chapter 2.2	Pressure p_{max} (bar)	Available adjustments Chapter 2.3	Circuit symbol		
Pressure-limiting valve									
MV	41	Angle valve for pipeline installation	G 1/4	A, B, C, E, F	P: 700 R: 20	without coding, R, V			
	42		G 3/8						
	52		G 3/8						
	53		G 1/2						
	63		G 1/2						
	64		G 3/4						
Pressure-limiting valve and sequence valve									
MVS	41	Angle valve for pipeline installation	G 1/4	A, B, C, E, F	P: 700 R: 500	without coding, R			
	42		G 3/8						
	52		G 3/8						
	53		G 1/2						
	63		G 1/2			without coding, R, V			
	64		G 3/4						
	84		G 3/4					B, C, E	P: 400 R: 400
	85		G 1						
MVE	4	Screw-in valve	Stepped bore	A, B, C, E, F	P: 700 R: 350	without coding, R, V			
	5								
	6								
	8							B, C, E	P: 400 R: 100

Type	Size	Description	Ports (ISO 228-1)	Available pressure ranges Chapter 2.2	Pressure p_{max} (bar)	Available adjustments Chapter 2.3	Circuit symbol
MVP	4	Manifold mounting valve	Connection plate	A, B, C, E, F	P: 700 R: 350	without coding, R, V	
	5						
	6						
	8			B, C, E	P: 400 R: 350		
	8 ¹⁾			A ¹⁾	P: 700 R: 350	without coding	
SV	42	Straight-way valve for straight pipeline installa- tion	G 3/8	A, B, C, E, F	P: 700 R: 500	without coding	
	53		G 1/2				
	64		G 3/4				
	85		G 1	C, E	P: 315 R: 315		
Pressure-limiting valve (as shock valve) for pipeline installation							
DMV	41	Twin valve for hydraulic motor	G 1/4	B, C, E, F	P: 350 R: 350	without coding	
	42		G 3/8				
	52		G 3/8				
	53		G 1/2				
	63		G 1/2				
	64		G 3/4				
	84		G 3/4				
	85		G 1				
DMVN	42	Twin valve with anti- cavitation valve for cylinder ²⁾	G 3/8	B, C, E, F	P: 350 R: 20	without coding	
	53		G 1/2				
	64		G 3/4				
MVT	63	Single valve with through bores	G 1/2	B, C, E, F	P: 315 R: 315	without coding	
Pressure-limiting valve with free return flow via a bypass check valve							
MVCS	46	Angle valve for pipeline installation	G 3/8	B, C, E, F	P: 500 R: 500	without coding, R, V	
	56		G 1/2				
	66		G 3/4				

Type	Size	Description	Ports (ISO 228-1)	Available pressure ranges Chapter 2.2	Pressure p_{max} (bar)	Available adjustments Chapter 2.3	Circuit symbol
SVC	46	Straight-way valve for straight pipeline installation	G 3/8	B, C, E, F	P: 500 R: 500	without coding	
	56		G 1/2				
	66		G 3/4				
	47		G 3/8 (A)				
	58		G 1/2 (A)				
	69		G 3/4 (A)				

- 1) Conical seat version, service life limited to 50000 cycles; the valve then has to be replaced.
- 2) Anti-cavitation valves are intended to compensate for volume changes in order to prevent vacuum formation in hydraulic cylinders.

2.2 Pressure range and flow rate

Coding	Pressure p_{max} (bar)	Factory-set pressure setting (bar) **	Flow rate Q_{max} (l/min)			
			Size			
			4	5	6	8
A	140 - 700	450	12	20	40	--
B	100 - 500 (400 *)	400	20	40	75	160
C	60 - 315	315				
E	30 - 160	160				
F	5 - 80	80				



* for size 8

** if pressure specification is missing when ordering

i INFORMATION

Lowest achievable pressure depends on the inherent flow resistance (with relieved spring) and the flow rate.

2.3 Adjustment

Coding	Description	Circuit symbol
without coding	Fixed, tool adjustable	
R	Manually adjustable (Wing bolt + wing nut)	
V	Turning knob (self-locking)	

i INFORMATION

Factory-set sealing possible (specify in plain text)
Only with adjustment "without coding"

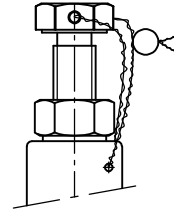

2.4 Damping

Coding	Description
without coding	damped (series)
X	undamped

3 Parameters

3.1 General data

Design	Directly controlled pressure valve, in ball seated design
Material	<ul style="list-style-type: none"> ▪ MV: Zinc die casting: Standard version for normal operating cases ▪ MVS, MVCS: Spheroidal casting: For rough operating conditions. For systems where mechanical shocks or vibrations are unavoidable (vehicle construction). Also in the case of pressure surges in the return line. ▪ MVE, MVP, SV, DMV, DMVN, MVT, SVC: Steel
Surface protection	Steel parts and spheroidal casting, electrogalvanised, spring dome made from zinc die casting, untreated
Attachment	Depending on the type, freely hanging in the pipeline or attached via through bore or screw-in or manifold mounting
Installation position	any
Flow direction	P → R, with SVC and MVCS, free return flow R → P (Q_{max} see Chapter 2.2, "Pressure range and flow rate")
Hydraulic fluid	Hydraulic fluid, according to DIN 51 524 Parts 1 to 3; ISO VG 10 to 68 according to DIN ISO 3448 Viscosity range: 4 - 1500 mm ² /s Optimal operating range: approx. 10 - 500 mm ² /s Also suitable for biologically degradable hydraulic fluids type HEPG (polyalkylene glycol) and HEES (synthetic ester) at operating temperatures up to approx. +70°C.
Cleanliness level	ISO 4406 <hr style="width: 25%; margin-left: 0;"/> 21/18/15...19/17/13
Temperatures	Environment: approx. -40 to +80 °C, hydraulic fluid: -25 to +80 °C, pay attention to the viscosity range. Start temperature: down to -40 °C is permissible (take account of the start viscosities!), as long as the steady-state temperature is at least 20 K higher during subsequent operation. Biologically degradable hydraulic fluids: note manufacturer specifications. With consideration for the seal compatibility, not above +70°C.

3.2 Weight

Type	Size			
	4	5	6	8
MV	= 0.2 kg	= 0.3 kg	= 0.5 kg	--
MVS	= 0.2 kg	= 0.3 kg	= 0.5 kg	= 2.0 kg
MVE	= 0.2 kg	= 0.3 kg	= 0.4 kg	= 1.0 kg
MVP	= 0.3 kg	= 0.5 kg	= 0.8 kg	= 1.6 kg
SV	= 0.2 kg	= 0.3 kg	= 0.7 kg	= 0.9 kg
DMV	= 0.7 kg	= 1.3 kg	= 1.8 kg	= 4.5 kg
DMVN	= 0.8 kg	= 1.5 kg	= 2.4 kg	--
MVT	--	--	= 1.3 kg	--
MVCS	= 0.3 kg	= 0.4 kg	= 0.7 kg	--
SVC	= 0.3 kg	= 0.4 kg	= 0.9 kg	--

3.3 Characteristic lines

Viscosity of the hydraulic fluid approx. 50 mm²/s

Characteristic curve shown based on the example of MV..C (basic trend, certain differences are present depending on the pressure gradient and depending on the housing shape of the various basic types).

The characteristic lines change to positive Δp values in the event of increased return pressure.

Size 4

Example: MV 42C

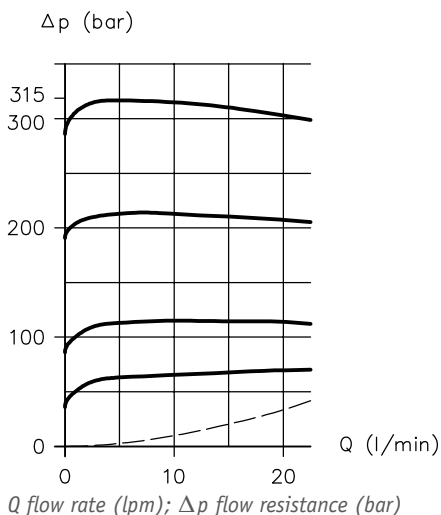

Size 5

Example: MV 53C

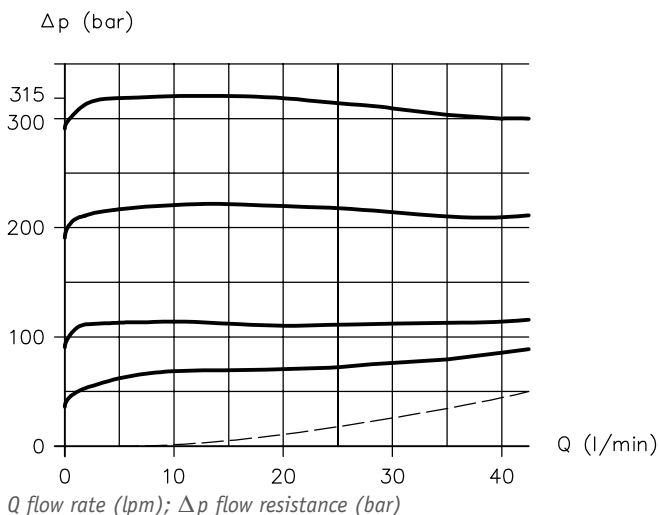

Size 6

Example: MV 64C

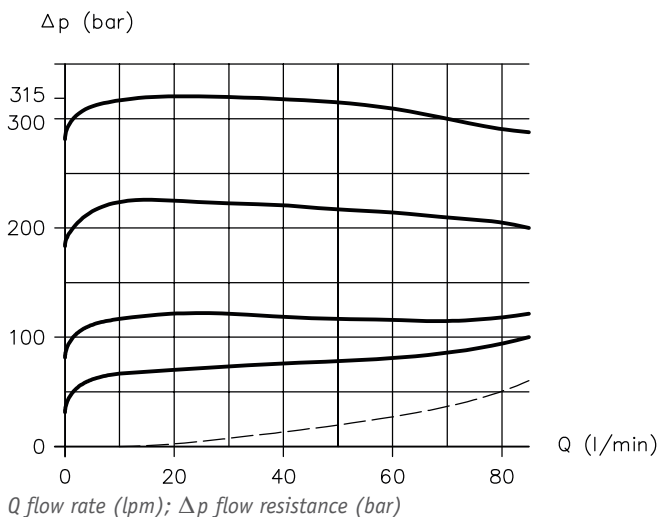

Size 8

Example: MVS 85C

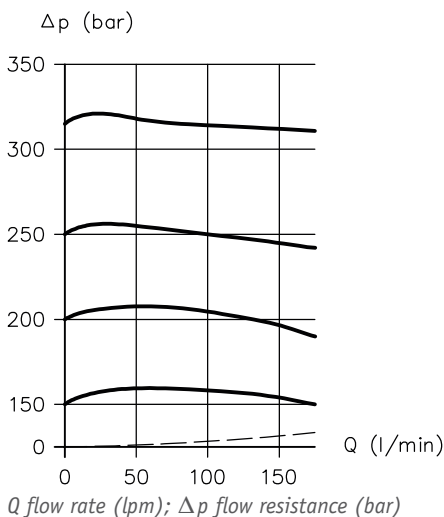

Flow direction R → P with type MVC.. and SVC..

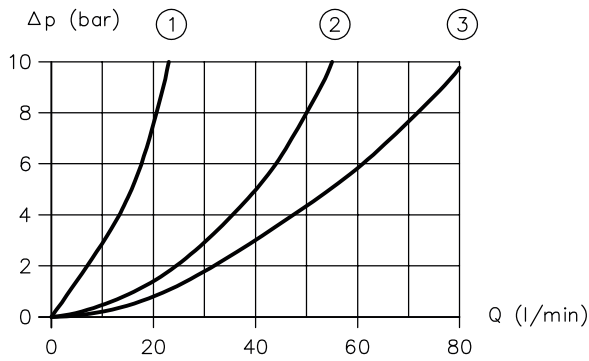

Q flow rate (lpm); Δp flow resistance (bar)

- 1 Size 4
- 2 Size 5
- 3 Size 6

! NOTICE
 Inherent flow resistance in the event of relieved spring (static pressure value 0 bar).
 Pressures below this boundary are not achievable, see Chapter 3.3, "Characteristic lines"

Pressure change

Rough reference values (for the closed valve) per 1 revolution on the adjusting screw

Pressure (bar)		Travel f_{max} (mm) / Δp (bar) per 1 revolution			
		Size 4	Size 5	Size 6	Size 8
A	140 - 700	4.5 / 195 (4.3 / 220)	8.4 / 105 (9.1 / 140)	7.4 / 120 (7 / 180)	--
B	100 - 500 (400)	6.3 / 100 (6.1 / 110)	9.7 / 65 (10 / 90)	7.9 / 80 (7 / 130)	9 / 68
C	60 - 315	7.1 / 55 (6.5 / 65)	7.7 / 51 (7.2 / 80)	10.2 / 35 (9.3 / 62)	13 / 37 (12.8 / 57)
E	30 - 160	10.5 / 19 (8 / 27)	12 / 17 (11.2 / 26)	11.5 / 17.5 (10 / 29)	12.5 / 20 (12.4 / 30)
F	5 - 80	10.5 / 9.5 (7.2 / 15)	11.5 / 9 (7.3 / 20)	12.5 / 8 (9.7 / 15)	--

Values in brackets apply for type SV and SVC

! NOTICE
 Pressure adjustment only with monitoring of the pressure gauge, see Chapter 6.1, "Setting instructions"

4 Dimensions

All dimensions in mm, subject to change.

4.1 MV

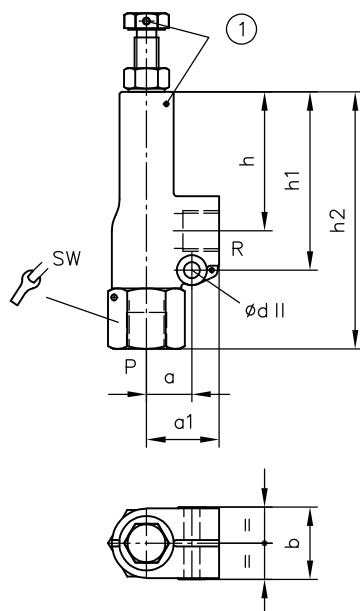

SW = Wrench size

1 Sealing option

Size	a	a1	b	h	h1	h2	Ød	SW
4	15	24	24	46	59	85	5,3	22
5	18	30	29	49	66	95	6,4	27
6	20	35	36	62	82	117	6,4	32

Adjustment

without coding
fixed

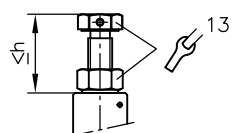

Coding R
Manually adjustable

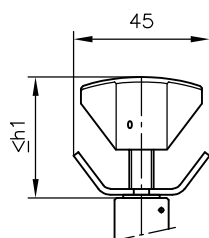

Size	h	h1
4	26	40
5	31	42
6	31	44

4.2 MVS

MVS 4, MVS 5, MVS 6

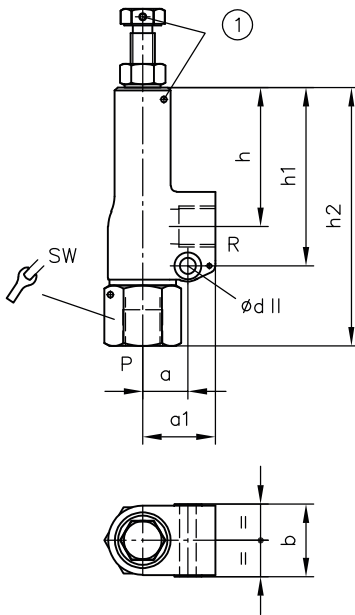

SW = Width across flats

1 Sealing option

Size	a	a1	b	h	h1	h2	$\varnothing d$	SW
4	15	24	24	46	59	85,5	5,5	22
5	18	30	29	49	66	95	6,5	27
6	20	35	36	62	82	117	6,5	32

Adjustment

without coding
fixed

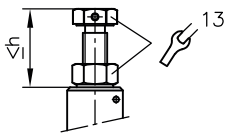

Coding R
Manually adjustable

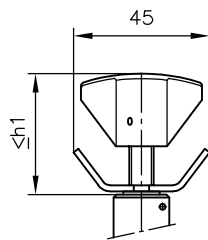

Coding V
Turning knob

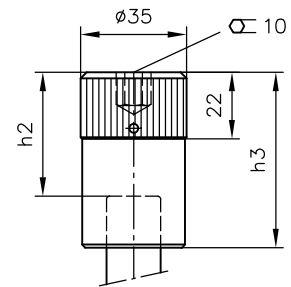

Size	h	h1	h2	h3
4	26	40	41	58
5	31	42	41	58
6	31	44	47	64

MVS 8

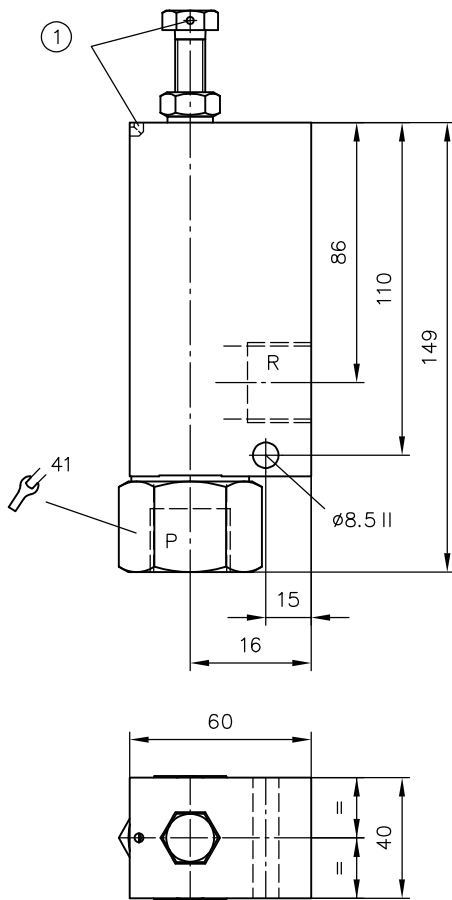

1 Sealing option

Adjustment

without coding
fixed

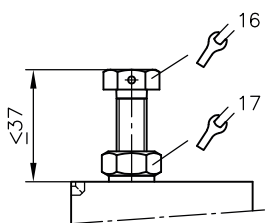

Coding **R**
Manually adjustable

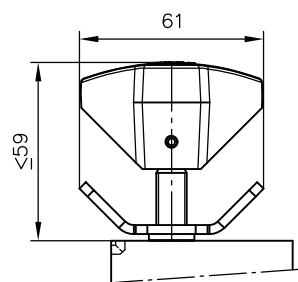

4.3 MVE

MVE 4

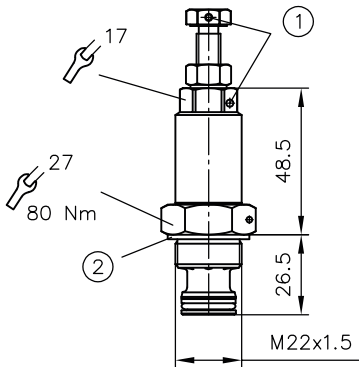

- 1 Sealing option
- 2 Sealing ring DIN 7603-St-A22x27x1.5

Adjustment

without coding
fixed

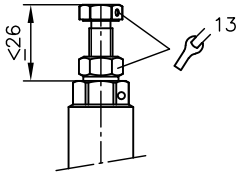

Coding **R**
Manually adjustable

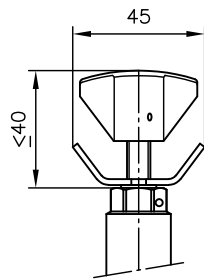

Coding **V**
Turning knob

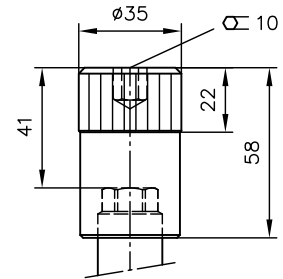

MVE 5, MVE 6, MVE 8

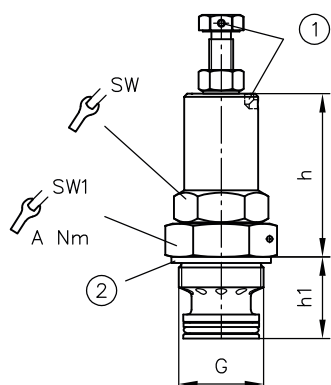

SW = Width across flats

- 1 Sealing option
- 2 Sealing ring

Size	h	h1	G	SW	SW1	A	Sealing ring DIN 7603..
5	54	27	M28x1.5	27	32	160	A28x34x2 (St)
6	66	32	M30x1.5	30	36	200	A30x36x2 (St)
8	91	40	M40x1.5	41	46	380	A40x49x2 (St)

Adjustment

without coding
fixed

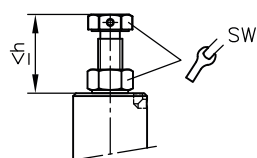

SW = Width across flats

Coding R
Manually adjustable

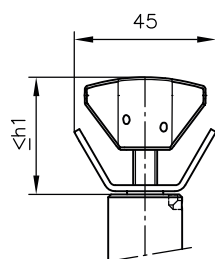

Coding V
Turning knob (not with MVE 8)

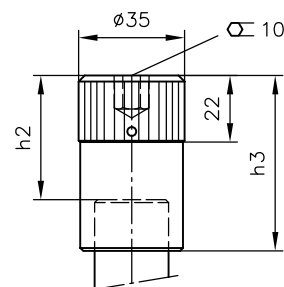

Size	h	h1	h2	h3	SW
5	29	42	41	58	13
6	31	44	47	64	13
8	37	40	--	--	17

Mounting hole

MVE 4, 8

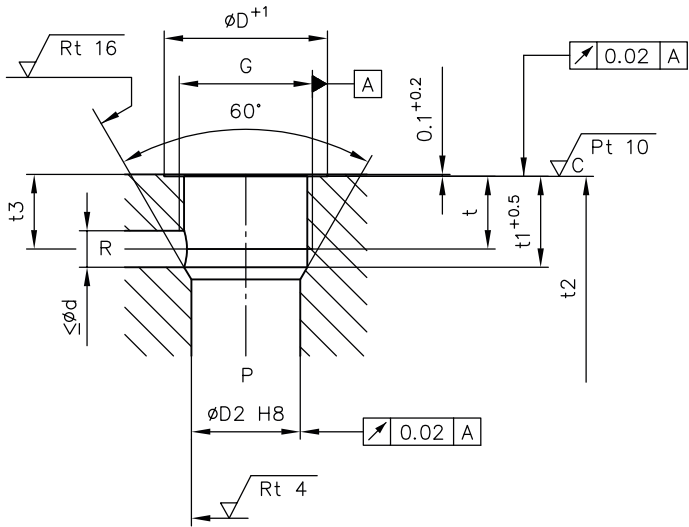

MVE 5, 6

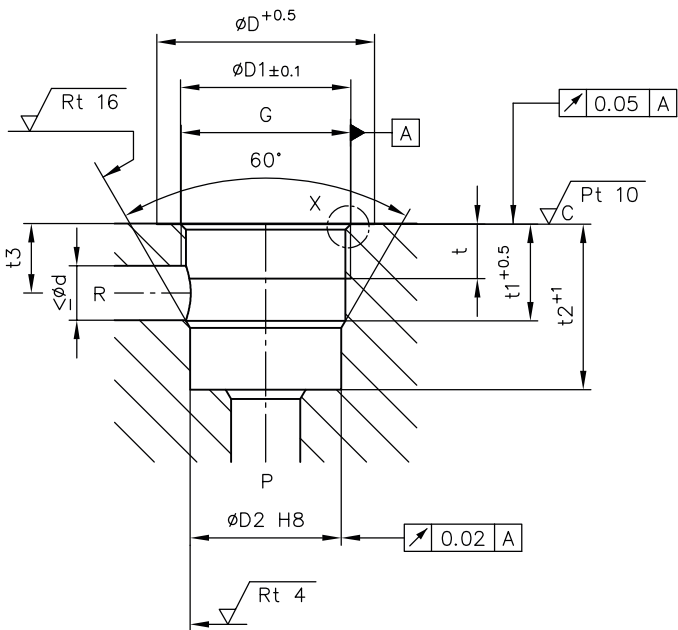

Detail of X

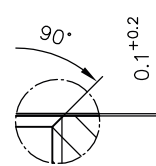

Size	G	$\varnothing D$	$\varnothing D1$	$\varnothing D2$	$\varnothing d$	t	t1	t2	t3
4	M22x1.5	27	--	18	6	12	15	26	12
5	M28x1.5	36	28,2	25	9	9	16	27,4	11,5
6	M30x1.5	38,5	30,4	25	12	10	19	35	14
8	M40x1.5	49	--	36	16	12	27	40	19

4.4 MVP

MVP 4

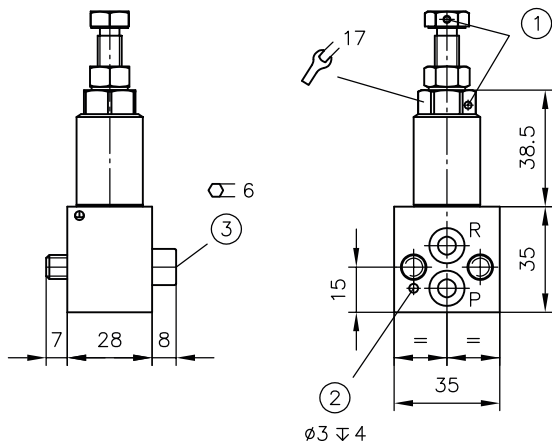

- 1 Sealing option
- 2 Centring pin
- 3 Cylinder screw ISO 4762-M8x35-8.8-A2K

Adjustment

without coding
fixed

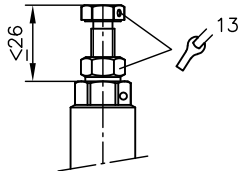

Coding R
Manually adjustable

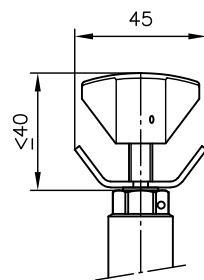

Coding V
Turning knob

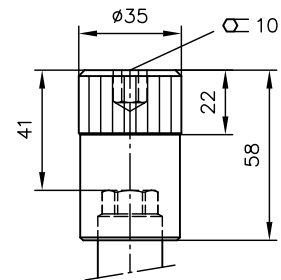

Base plate hole pattern

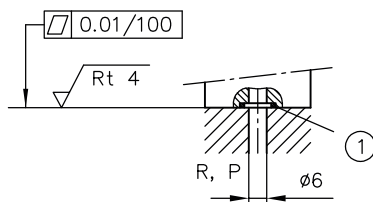

- 1 O-ring 8.00 x 2.00 NBR 90 Sh

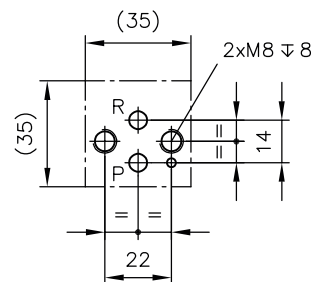

MVP 5, MVP 6, MVP 8

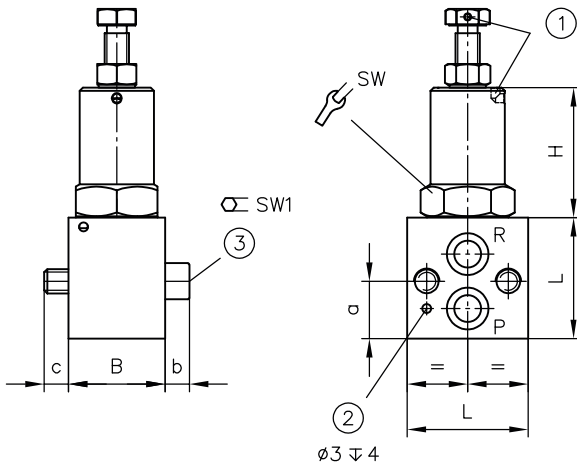

SW = Width across flats

- 1 Sealing option
- 2 Centring pin
- 3 Cylinder screw

Size	B	L	H	a	b	c	SW	SW1	Cylinder screw ISO 4762
5	32	40	43	19	8	8	13	6	M8x40-8.8-A2K
6	35	50	52	24	10	10	30	8	M10x45-8.8-A2K
8	50	59,4	77	29,4	12	15	41	10	M12x65-8.8-A2K

Adjustment

without coding
fixed

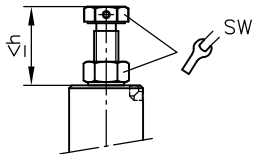

SW = Width across flats

Coding R
Manually adjustable

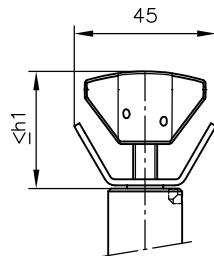

Size	h	h1	SW
5	29	42	13
6	31	44	13
8	37	40	17

Base plate hole pattern



1 O-ring

Size	L	ϕd	a	b	g	O-ring
5	40	9	27	18	M8, 10 deep	10.00x2.00
6	50	12	34	22	M10, 12 deep	13.95x2.62
8	59.4	16	40	26	M12, 17 deep	18.76x2.62

MVP 8 A

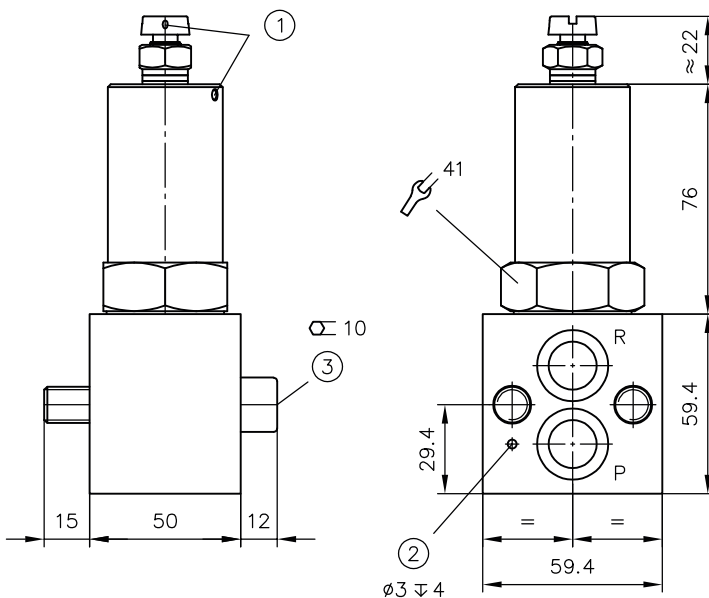

- 1 Sealing option
- 2 Centring pin
- 3 Cylinder screw

Base plate hole pattern

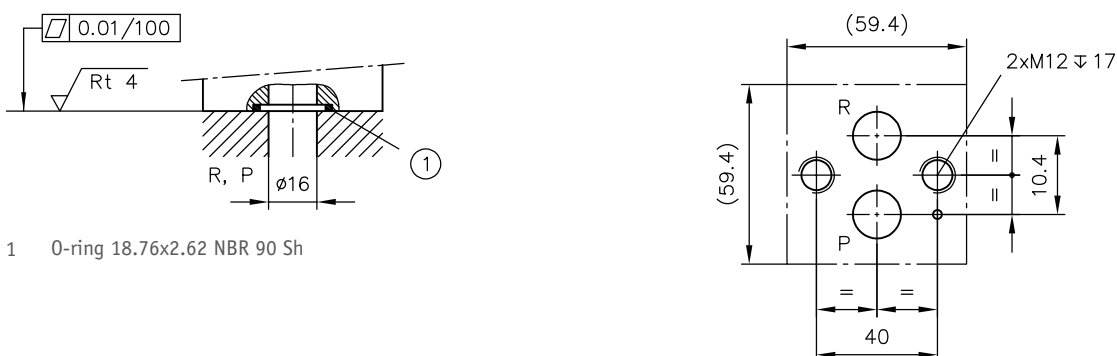

1 O-ring 18.76x2.62 NBR 90 Sh

4.5 SV

SV 4, SV 5, SV 6, SV 8

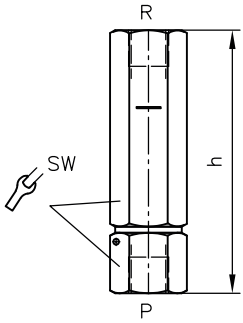

SW = Width across flats

Size	h	SW
4	87	22
5	104	27
6	129	32
8	157	41

4.6 DMV

DMV 4

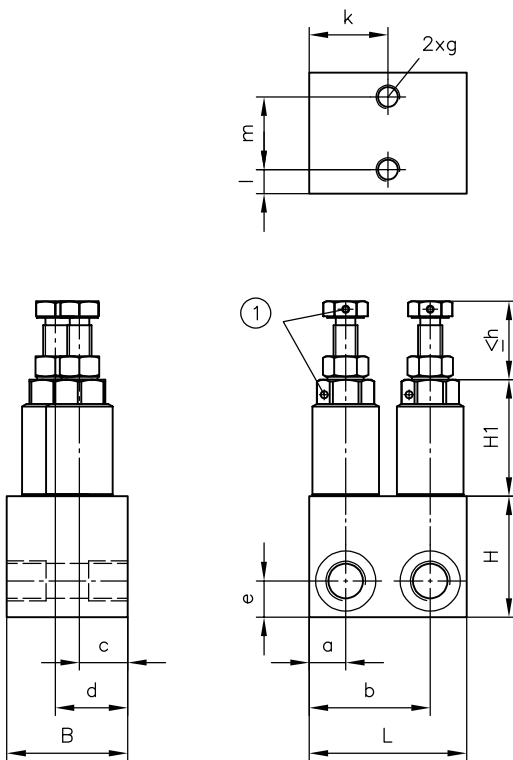

1 Sealing option

DMV 5, DMV 6, DMV 8

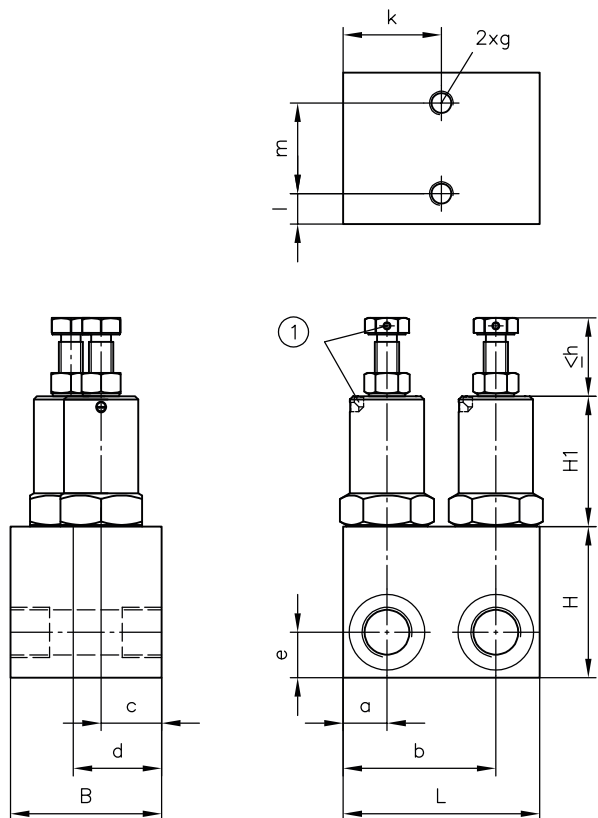

1 Sealing option

Size	B	L	H	H1	h	a	b	c	d	e	k	l	m	g
4	40	52	40	38,5	26	12	40	16	24	12	26	8	24	M8, 10 deep
5	50	65	50	43	29	14,5	50,5	20	30	15	32,5	10	30	M8, 10 deep
6	60	75	60	52	31	16,5	58,5	23	37	18	37,5	10	40	M10, 12 deep
8	80	96	80	77	37	21	75	30,5	49,5	25	48	10	60	M10, 12 deep

4.7 DMVN

DMVN 42

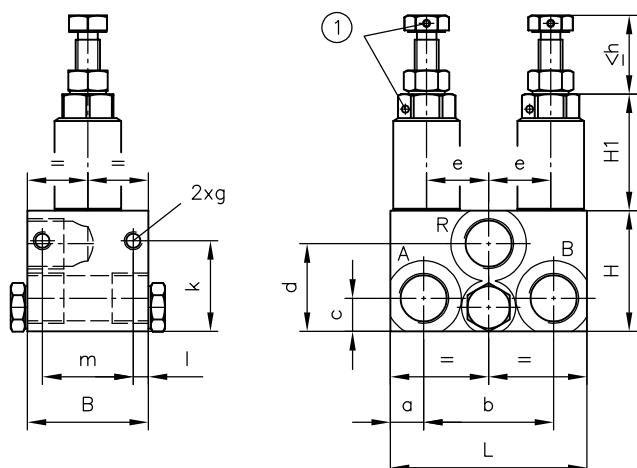

1 Sealing option

DMVN 53, DMVN 64

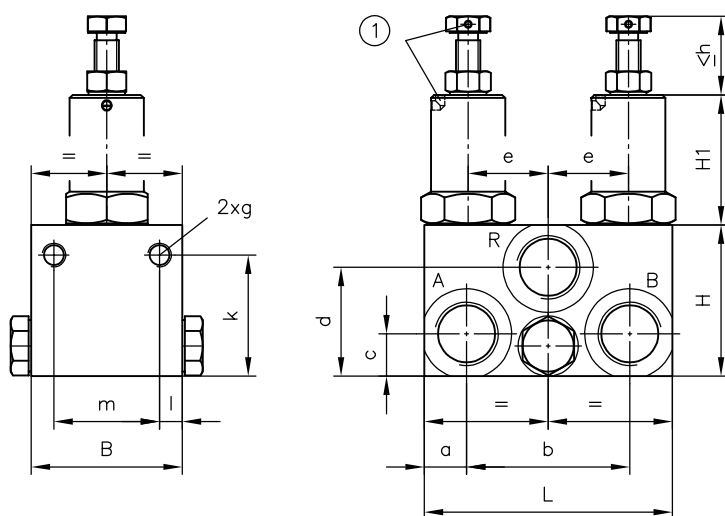

1 Sealing option

Size	B	L	H	H1	h	a	b	c	d	e	k	l	m	g
42	40	65	40	38,5	26	11	43	11	29	20,5	30	5	30	M6, 10 deep
53	50	82	50	43	29	14	54	14	36	26,5	40	7,5	35	M8, 12 deep
64	60	97	60	52	31	16,5	64	16,5	44	32	50	9	42	M10, 12 deep

4.8 MVT

MVT 63

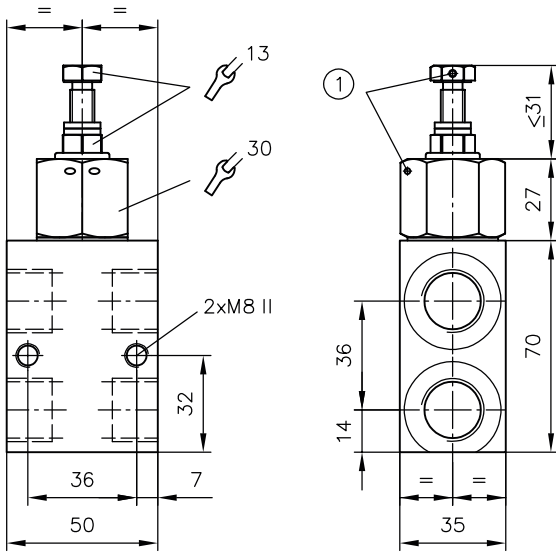

1 Sealing option

4.9 MVCS

MVCS

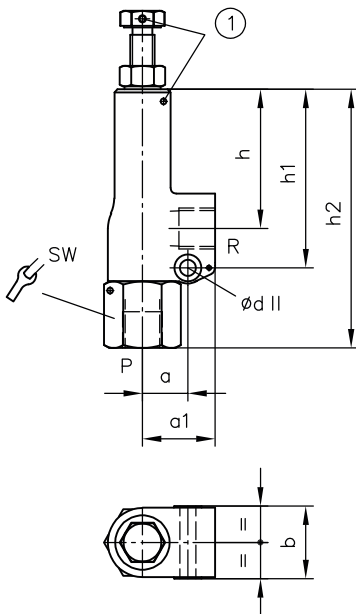

SW = Width across flats

1 Sealing option

Size	a	a1	b	h	h1	h2	$\varnothing d$	SW
4	15	24	24	46	59	85,5	5,5	22
5	18	30	29	49	66	100,5	6,5	27
6	20	35	36	62	82	122	6,5	32

4.10 SVC

SVC 4, SVC 5, SVC 6

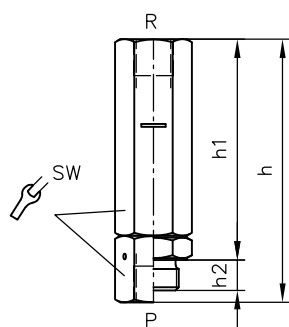

SW = Width across flats

Size	h	h1	h2	SW
4	87	73	10	22
5	110	90	12	27
6	132	112	13,5	32

Observe the document B 5488 "General operating instructions for assembly, commissioning, and maintenance."

5.1 Intended use

This product is intended exclusively for hydraulic applications (fluid technology).

The user must observe the safety measures and warnings in this document.

Essential requirements for the product to function correctly and safely:

- ▶ All information in this documentation must be observed. This applies in particular to all safety measures and warnings.
- ▶ The product must only be assembled and put into operation by specialist personnel.
- ▶ The product must only be operated within the specified technical parameters described in detail in this document.
- ▶ All components must be suitable for the operating conditions when using an assembly.
- ▶ The operating instructions for the components, assemblies and the specific complete system must also always be observed.

If the product can no longer be operated safely:

1. Remove the product from operation and mark it accordingly.
 - ✓ It is then not permitted to continue using or operating the product.

5.2 Assembly information

The product must only be installed in the complete system with standard and compliant connection components (screw fittings, hoses, pipes, fixtures etc.).

The product must be shut down correctly prior to disassembly (in particular in combination with hydraulic accumulators).

DANGER

Sudden movement of the hydraulic drives when disassembled incorrectly

Risk of serious injury or death

- ▶ Depressurise the hydraulic system.
- ▶ Perform safety measures in preparation for maintenance.

5.3 Operating instructions

Observe product configuration and pressure/flow rate.

The statements and technical parameters in this document must be strictly observed.

The instructions for the complete technical system must also always be followed.

NOTICE

- ▶ Read the documentation carefully before usage.
- ▶ The documentation must be accessible to the operating and maintenance staff at all times.
- ▶ Keep documentation up to date after every addition or update.

CAUTION

Overloading components due to incorrect pressure settings.

Risk of minor injury. Parts may burst or fly off, and uncontrolled leakage of hydraulic fluid.

- Pay attention to the maximum operating pressure of the pump, valves and fittings.
- Always monitor the pressure gauge when setting and changing the pressure.

Purity and filtering of the hydraulic fluid

Fine contamination can significantly impair the function of the product. Contamination can cause irreparable damage.

Examples of fine contamination include:

- Swarf
- Rubber particles from hoses and seals
- Dirt due to assembly and maintenance
- Mechanical debris
- Chemical ageing of the hydraulic fluid

! NOTICE

New hydraulic fluid from the manufacturer may not have the required purity.

Damage to the product is possible.

- ▶ Filter new hydraulic fluid to a high quality when filling.
- ▶ Do not mix hydraulic fluids. Always use hydraulic fluid that is from the same manufacturer, of the same type, and with the same viscosity properties.

For smooth operation, pay attention to the cleanliness level of the hydraulic fluid (cleanliness level [see Chapter 3, "Parameters"](#)).

Additionally applicable document: [D 5488/1](#) oil recommendations

5.4 Maintenance information

Check regularly (at least once a year) by visual inspection whether the hydraulic connections are damaged. If external leakages are found, shut down and repair the system.

Clean the surface of the device regularly (at least once a year) (dust deposits and dirt).

6 Other information

6.1 Setting instructions

If the desired pressure is indicated when ordering (e.g. MV 53 C-250), then the valves will be delivered with this setting. In the case of adjustable valves, washers prevent unauthorised raising of the desired pressure. In the case of valves with fixed settings, the max. pressure is limited.

The number of washers and the limitation of the maximum pressure may slightly vary due to the sum of tolerances. If the pressure specification is missing, the valves will be delivered with the factory-set pressure setting.

! NOTICE

- ▶ Only perform a pressure adjustment that is potentially required at the installation location when monitoring the pressure gauge and with the pump running.
- ▶ The pressure adjustment may only be carried out if there is no pressure on the return side (R).

Reduction of the setting

Pressure gauge on the pressure line (pressure channel).

1. Type MV., DMV(N): release lock nut (possibly remove lead seal).
Type SV(C): release grub screw.
2. Turn adjustment device in anti-clockwise direction and observe pressure gauge while doing so.
3. Limit the maximum adjustable pressure by inserting washers (item 11) if necessary.
4. After making the setting: Tighten lock nut or grub screw.
Type MV.: Potentially reseal valves against authorised adjustment.

Increase of the setting

1. Observe pressure p_{max} , see Chapter 2.2, "Pressure range and flow rate"
2. Procedure as above.

Adjustment is carried out clockwise. If the adjustable version of the washers prevent the higher setting (turning knob sitting on the lock nut), as many washers can be removed after the roll pin and the wing lock nut are disassembled as are required to achieve the new, higher pressure (measure before and after adjustment). Counter and reattach turning knob with roll pin.

i INFORMATION

The pressure value read from the pressure gauge which occurs when setting or adjusting with the pump running relates to the flow rate on the pump side. Due to a flow rate dependency, there may be slightly altered response pressures in the event of different pump delivery flows (extreme case, hand pump $Q \approx 0$ lpm). If necessary, supplement pressure specification with plain text "at start of response" (start of dripping).

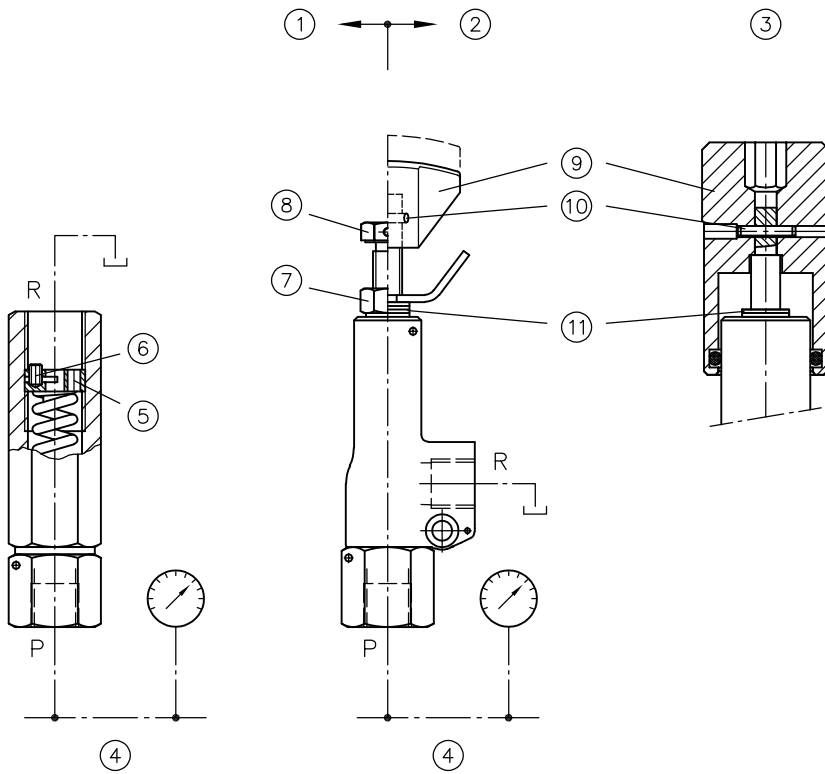

- 1 **fixed**
- 2 **manually adjustable**
Adjustment device coding R
- 3 **manually adjustable**
Adjustment device coding V
- 4 Pressure line
- 5 Threaded screw
- 6 Grub screw
- 7 Lock nut
- 8 Adjusting screw
- 9 Turning knob
- 10 Roll pin
- 11 Washer

References

Additional versions

- Pressure-limiting valve (installation kit) type MV: D 7000 E/1
- Pressure-limiting valve, with unit approval type MV .X: D 7000 TUV
- Pressure-limiting valve and pre-load valve type MVG, MVE, and MVP: D 3726
- Pressure valve type CMV, CMVZ, CSV and CSVZ: D 7710 MV
- Pressure-limiting valve, with unit approval type CMVX: D 7710 TUV

